



cofan
home

CATÁLOGO GENERAL



2017

www.cofan.es



2017 CATÁLOGO GENERAL

¿QUIÉNES SOMOS? / QUI SOMMES-NOUS? / WHO WE ARE?
CHI SIAMO? / QUEM SOMOS?



Hacemos de tu casa un hogar.
Nous faisons de votre maison un foyer.
We make a home of your house.
Rendiamo la vostra casa un luogo perfetto.
Fazemos da sua Casa um Lar.



Productos cuidadosamente seleccionados.
Produits soigneusement sélectionnés.
Carefully selected products.
Prodotti accuratamente selezionati.
Produtos cuidadosamente selecionados.

El saber de la experiencia.
Le savoir de l'expérience.
The knowledge of the experience.
Il sapere dell'esperienza.
O saber da experiência.



La comodidad del día a día.
Le confort au jour le jour.
The comfort of everyday life.
Il comfort tutti i giorni della vita.
A comodidade do dia a dia.



Diseño y evolución a tu medida.
Conception et évolution à votre mesure.
A bespoke design and evolution.
Progettazione e sviluppo a vostra misura.
Desenho e evolução à sua medida.



● ÍNDICE / INDEX / INDEX
INDICE / ÍNDICE



6

COCINA
CUISINE
KITCHEN
CUCINA
COZINHA

106

BAÑO
SALLE DE BAIN
BATHROOM
BAGNO
CASA DE BANHO

124

LIMPIEZA
NETTOYAGE
CLEANING
PULIZIA
LIMPEZA

166

ALMACENAJE
RANGEMENT
STORAGE
CONTENITORI
ARRUMAÇÃO

180

CALEFACCIÓN
CHAUFFAGE
HEATING
RISCALDAMENTO
CALEFAÇÃO

COCINA / CUISINE / KITCHEN CUCINA / COZINHA

8

Sartenes y Ollas

Poêles et Casseroles

Frying Pans and Pots

Tegami e Pentole

Frigideiras E Panelas

26

Paelleras

Poêles á paella

Paella pans

Padelle per Paella

Paelheira

36

Utensilios

Ustensiles

Kitchen utensils

Utensili

Utensilios

58

Cuberteria y cuchillería

Couverts et Coutellerie

Cutlery

Posateria e Coltelleria

Talheres e Cutelaria

80

Cristalería y vajillas

Verrerie et vaisselles

Glassware and crockery

Cristalleria e stoviglie

Vidros e louças

90

Accesorios

Accessoires

Accessories

Accessori

Acessórios



COCINA / CUISINE / KITCHEN / CUCINA / COZINHA

Sartenes y Ollas / Poêles et Casseroles / Frying Pans and Pots / Tegami e Pentole / Frigideiras e Panelas



Reggia



Mod. Reggia

Bateria de Cocina de Aluminio Forjado Antiadherente. Permite cocinar sin grasas ni aceite y lavarla en lavavajillas. Apta para todo tipo de fuegos, con la variedad de cocinas de inducción incluidas. Manejable y cómoda, con gran capacidad de conducción del calor y asas fabricadas en dos componentes muy agradables al tacto, antideslizantes y sin posibilidad de calentamiento.

Batterie de Cuisine en Aluminium Forgé Antiadhésif permettant une cuisine sans matière grasse ni huile, un lavage au lave-vaisselle et une utilisation sur tout type de feux, même sur plaques à induction. Batterie de cuisine Cofanhome maniable permettant une répartition optimale de la chaleur. Poignées bi-matières, très agréables au toucher, antidérapantes, et qui ne chauffent pas.

Non-stick forged aluminium kitchenware. It allows you to cook fat free and without oil, dishwasher safe and it is suitable for all type of stove burners, (induction hobs included). Comfortable and easy to handle kitchenware Cofanhome with a great capacity of heat conduction and handles made of two anti-slip components pleasant to the touch. No possibility of warming.

Set da cucina in alluminio forgiato antiaderente. Permette di cucinare senza grassi o oli. Si può lavare in lavastoviglie ed è adatta per tutte le tipologie di cottura, tra cui quella ad induzione. Il set da cucina Cofanhome è maneggevole e confortevole grazie ad un'ottima diffusione del calore e ai manici fabbricati con due componenti che li rendono molto piacevoli al tatto, antiscivolo e senza possibilità di riscaldamento degli stessi.

Panelas de cozinha antiaderentes de alumínio forjado que lhe permite cozinhar sem gordura ou óleo, pode lavá-las na máquina da louça e são adequadas para todos os tipos de fogões, incluindo indução. Panelas de cozinha Cofanhome manejáveis e cómodas com grande capacidade de condução de calor e apegas feitas de dois componentes muito agradáveis ao toque, antiderrapantes e sem a possibilidade de aquecimento das mesmas.



COCINA / CUISINE / KITCHEN / CUCINA / COZINHA

Sartenes y Ollas / Poêles et Casseroles / Frying Pans and Pots / Tegami e Pentole / Frigideiras e Panelas

Mod. Reggia

CACEROLA ALTA ANTIADHERENTE
MARMITE ANTIADHERENTE
STOCK POT NON STICK
CASSERUOLA ALTA ANTIADERENTE
PANELA C/ASAS ANTIADERENTE

CACEROLA ANTIADHERENTE
FAITOUT ANTI-ADHESIVE
CASSEROLE NON STICK
CASSERUOLA ANTIADERENTE
CAÇAROLA ANTIADERENTE



4100 1562: Ø200mm
€: 18,25 / IVA: 22,07
1/4

4100 1563: Ø240mm
€: 21,25 / IVA: 25,70
1/4

4100 1564: Ø280mm
€: 26,25 / IVA: 31,76
1/4

4100 1552: Ø160mm
€: 13,33 / IVA: 16,13
1/4

4100 1553: Ø200mm
€: 16,08 / IVA: 19,46
1/4

4100 1554: Ø240mm
€: 20,05 / IVA: 24,26
1/4

4100 1555: Ø280mm
€: 23,58 / IVA: 28,54
1/4



SARTÉN ANTIADHERENTE DE ALUMINIO
POÊLE BRIDE ANTI-ADHESIVE
FRYING PAN NON STICK
PADELLA HONDA ANTIADERENTE
SERTĂ FUNDA ANTIADERENTE



4100 1332: Ø180mm
€: 8,87 / IVA: 10,74
1/6

4100 1333: Ø200mm
€: 9,86 / IVA: 11,94
1/6

4100 1334: Ø220mm
€: 11,36 / IVA: 13,75
1/6

4100 1335: Ø240mm
€: 12,52 / IVA: 15,15
1/6

4100 1336: Ø260mm
€: 13,43 / IVA: 16,26
1/6

4100 1337: Ø280mm
€: 14,65 / IVA: 17,73
1/6

4100 1338: Ø300mm
€: 16,31 / IVA: 19,74
1/6

Mod. Reggia

FREIDORA/WOK ALUMINIO + CESTO
FRITEUSE/WOK
FRYING SET/WOK
PADELLA PER FRIGGERE + CASTELLO
FRITADEIRA/WOK



4100 1321: Ø260mm
€: 17,50 / IVA: 21,17

 1/6

SARTÉN HONDA ANTIADHERENTE ALUMINIO
POÊLE À MANCHE ANTIADHÉSIF
DEEP FRYPAN NON-STICK
PADELLA PROFONDA ANTIADERENTE
SERTĂ FUNDA ANTIADERENTE



4100 1322: Ø260mm
€: 16,08 / IVA: 19,46

 1/6

ASADORA ANTIADHERENTE ALUMINIO
GRILL ANTI-ADHESIVE
GRILL NON STICK
GRIGLIA PADELLA ANTIADERENTE
GRELHADOR ANTIADERENTE



4100 1323: Ø280mm
€: 14,71 / IVA: 17,80

 1/10

COCINA / CUISINE / KITCHEN / CUCINA / COZINHA

Sartenes y Ollas / Poêles et Casseroles / Frying Pans and Pots / Tegami e Pentole / Frigideiras e Panelas



Atrani

Mod. Atrani

Sartenes de Aluminio Forjado con antiadherentes de efecto "Piedra", mangos agradables al tacto y conductivos del calor. Pensadas para imprimirles robustez y facilidad de limpieza. Posibilidad de uso en todo tipo de fuegos. Es posible cocinar sin aceite ni grasas además de permitir la práctica de una cocina mucho más sana sin perder los mejores aromas y sabores.

Poêles en aluminium forgé antiadhésives effet "Pierre" et manche agréable au toucher et bonne conduction de la chaleur. Conçues pour leur robustesse et leur facilité de nettoyage. Possibilité d'utilisation sur tout type de feux. Il est possible de cuisiner sans huile ni ajout de matières grasses permettant une cuisine plus saine sans perdre les meilleurs arômes et les saveurs.

Non-stick forged aluminium saucepans, "Stone" effect and handles pleasant to the touch with heat conduction. They are thought to bring sturdiness and ease of cleaning. Possibility of use in any kind of stove burners. It is also possible to cook fat free and without oil. In addition, they enable cooking a healthier food without losing the best aromas and flavours.

Padelle antiaderenti in alluminio forgiato, effetto "pietra" e manici comodi al tatto. Alta conduzione termica, robuste e di facile pulizia. È possibile utilizzarle su tutti i tipi di fuochi. Possibilità di cucinare senza olio o grasso, consentendo cotture molto più sane, senza perdere i migliori aromi e sapori.

Sertãs de alumínio forjado com antiaderentes de efeito "Pedra" e pegas agradáveis ao toque e com condutores de calor. Foram pensadas para transmitir robustez e facilidade de limpeza. Podem ser usadas em todos os tipos de fogões. É possível cozinhar sem óleo ou gordura, além de permitir a prática de uma cozinha muito mais saudável sem perder os melhores aromas e sabores.

Mod. Atrani

SARTÉN (PIEDRA) DE ALUMINIO FORJADO
 POÊLE (PIEDRA) FORGÉE
 FRYING PAN (STONE) FORGED
 PADELLA (PIETRA) FORGIATO
 SERTÁ (PEDRA) FORJADO

4100 1302: Ø200mm
 €: 12,66 / IVA: 15,32
 1/6

4100 1304: Ø260mm
 €: 16,68 / IVA: 20,18
 1/6

4100 1303: Ø240mm
 €: 14,52 / IVA: 17,57
 1/6

4100 1305: Ø280mm
 €: 18,08 / IVA: 21,88
 1/6



ASADORA (PIEDRA) ALUMINIO FORJADO
 GRILL FORGÉE (PIEDRA)
 FORGED GRILL (STONE)
 GRIGLIA PADELLA (PIETRA) FORGIATO
 GRELHADOR FORJADO (PEDRA)

4100 1311: Ø280mm
 €: 18,39 / IVA: 22,26

1/6



COCINA / CUISINE / KITCHEN / CUCINA / COZINHA

Sartenes y Ollas / Poêles et Casseroles / Frying Pans and Pots / Tegami e Pentole / Frigideiras e Panelas



Mod. Caprese

Sartén de inducción con Antiadherente en el interior del forro de doble capa, para mayor resistencia y durabilidad excepcional en usos prolongados. Antiadherente de dos capas de recubrimiento exterior para facilitar la limpieza. Mango ergonómico de baquelita con acabado mate. Apto para todas las fuentes de calor (250°C).

Poêle pour feu à induction avec revêtement anti-adhésif double couche pour une plus grande résistance et une durabilité exceptionnelle avec des utilisations prolongées. Revêtement anti-adhésif deux couches pour faciliter le nettoyage. Manche ergonomique en bakélite finition mati. Convient à toutes les sources de chaleur (250°C).

Induction frying pan with double-layered non-stick interior for an exceptional resistance and durability in long-term uses. The exterior part consists of a double-layered non-stick coating to make the cleaning easier. Bakelite ergonomic handle with matt finish. Suitable for any heat source (250°C).

Padella a induzione, antiaderente, a doppio strato interno per una maggiore resistenza e una durata prolungata nel tempo. Rivestimento esterno a doppio strato per una facile pulizia. Manico con impugnatura ergonomica in bachelite con finitura opaca. Adatta per tutte le fonti di calore (250°C).

Sertã de indução, antiaderente no interior do forro de camada dupla, para maior resistência e durabilidade excepcional em uso prolongado. Antiaderente de duas camadas de revestimento exterior para facilitar a limpeza. Cabo ergonômico de baquelita com terminação mate. Indicado para todas as fontes de calor (250°C).



SARTÉN ANTIADHERENTE ALUMINIO
POÊLE ANTI-ADHÉSIVE ALUMINIUM
NON-STICK ALUMINIUM SAUCEPANS
PADELLA ANTIADERENTE IN ALLUMINIO
SERTÃ ANTIADERENTE ALUMÍNIO

4100 1381: Ø180mm
€: 7,94 / IVA: 9,61
1/6

4100 1384: Ø240mm
€: 11,11 / IVA: 13,44
1/6

4100 1387: Ø300mm
€: 15,71 / IVA: 19,01
1/6

4100 1382: Ø200mm
€: 8,67 / IVA: 10,49
1/6

4100 1385: Ø260mm
€: 12,37 / IVA: 14,97
1/6

4100 1388: Ø320mm
€: 16,86 / IVA: 20,40
1/6

4100 1383: Ø220mm
€: 9,78 / IVA: 11,83
1/6

4100 1386: Ø280mm
€: 13,71 / IVA: 16,59
1/6



Mod. Brasatto

Sartén de inducción con fondo rectificadо para una mejor preparación de los alimentos. Antiadherente en el interior del forro de doble capa, para mayor resistencia y durabilidad excepcional en usos prolongados. Antiadherente de dos capas de recubrimiento exterior para facilitar la limpieza. Mango ergonómico de baquelita con un acabado suave para mayor comodidad. **Anillo Antideflagrante que cambia de color** para transmitir la temperatura ideal para su uso. Apto para todas las fuentes de calor (250°C).

Poêle pour feu à induction avec fond rectifié pour une meilleure préparation des aliments. Revêtement anti-adhésif double couche, pour une plus grande résistance et une durabilité exceptionnelle pour des utilisations prolongées. Anti-adhésif deux couches extérieur pour faciliter le nettoyage. Manche ergonomique en bakélite finition lisse pour un plus grand confort. **Anneau qui change de couleur** indiquant la température idéale. Convient à toutes les sources de chaleur (250°C).

Induction frying pans with honeycomb surface to ensure a good food preparation. Double-layered non-stick interior for an exceptional resistance and durability in long-term uses. The exterior consists of a double-layered non-stick coating to make the cleaning easier. Ergonomic Bakelite handle with a smooth finish for a better comfort. **Explosion-proof ring that changes its colours** to notify the optimum temperature for cooking. Suitable for any heat source (250°C).

Padella a induzione con fondo rettificato per una migliore preparazione degli alimenti. Superficie interna antiaderente a doppio strato, per una maggiore resistenza e una durata prolungata nel tempo. Rivestimento esterno a doppio strato per una facile pulizia. Manico con impugnatura ergonomica con finitura morbida per un maggior comfort. **Anello antideflagrante che cambia colore** per trasmettere la temperatura per un utilizzo ideale. Adatta per tutte le fonti di calore (250°C).

Sertã de indução com fundo corrigido para uma melhor preparação dos alimentos. Antiaderente no interior do forro de dupla camada para uma maior resistência e durabilidade excepcional para uso prolongado. Antiaderente duas camadas de revestimento exterior para facilitar a limpeza. Cabo ergonómico de baquelita com um acabamento suave para maior conforto. **Anel de proteção contra explosões que muda de cor** para transmitir a temperatura ideal para o seu uso. Indicado para todas as fontes de calor (250°C).



SARTÉN ANTIADHERENTE ALUMINIO POÊLE ANTI-ADHÉSIVE ALUMINIUM NON-STICK ALUMINIUM SAUCEPANS PADELLA ANTIADERENTE IN ALLUMINIO SERTÃ ANTIADERENTE ALUMÍNIO

4100 1390: Ø160mm
€: 8,49 / IVA: 10,27
1/6

4100 1395: Ø260mm
€: 13,82 / IVA: 16,72
1/6

4100 1392: Ø200mm
€: 9,89 / IVA: 11,97
1/6

4100 1396: Ø280mm
€: 15,04 / IVA: 18,20
1/6

4100 1393: Ø220mm
€: 10,88 / IVA: 13,16
1/6

4100 1398: Ø320mm
€: 19,21 / IVA: 23,24
1/6

4100 1394: Ø240mm
€: 12,65 / IVA: 15,31
1/6



COCINA / CUISINE / KITCHEN / CUCINA / COZINHA

Sartenes y Ollas / Poêles et Casseroles / Frying Pans and Pots / Tegami e Pentole / Frigideiras e Panelas



Saucier

Mod. Saucier

Sartén Modelo Saucier "Chef" profesional, fabricada en Aluminio de alto espesor con rápida distribución del calor, recubrimiento antiadherente de dos capas con mango tubular y herrajes de acero inoxidable. Válidas para cocinas de gas, eléctricas, vitrocerámicas e incluso inducción. Contiene certificado alimentario y posibilidad de uso en lavavajillas.

Poêle Modèle Saucier "Chef" modèle Professionnel fabriquée en Aluminium très épais avec permettant une répartition rapide et optimale de la chaleur. Recouvrement antiadhésif de deux couches avec manche tubulaire et fixation en inox. Adapté pour la cuisine sur plaques au gaz, électriques, vitrocéramiques et induction. Dispose d'un Certificat alimentaire et peut être nettoyé au lave-vaisselle.

Saucepan Saucier "Chef" Professional manufactured in a high thickness aluminium with rapid heat distribution. Two layers of non-stick coating with tubular handle and stainless steel parts. They are suitable for gas and electric stoves, ceramic and induction hobs. Possibility to use the dishwasher.

Padella Modello Saucier "Chef", modello professionale fabbricato in Alluminio ad alto spessore, con una rapida distribuzione del calore. Rivestimento antiaderente a due strati con manico tubolare e accessori in acciaio inox. Utilizzabile in cucine a: gas, elettriche, ceramica e induzione. Contiene certificato alimentare e può essere lavato in lavastoviglie.

Sertã Modelo Saucier "Chef" Modelo profesional fabricada em alumínio de alta espessura com distribuição de calor rápida. Revestimento antiaderente de duas camadas com cabo tubular e acessórios em aço inoxidável. Válidas para gás, energia elétrica, vitrocerâmica, e mesmo indução. Contem certificado alimenticio e possibilidade de uso em máquinas de lavar louça.

SARTÉN PROFESIONAL DE ALUMINIO CON MANGO INOX POÊLE INOX ANTI-ADHESIVE FRYING PAN ST. STEEL NON STICK PADELLA INOX ANTIADERENTE SERTÃ INOX ANTIADERENTE



4100 1351: Ø180mm

€: 12,03 / IVA: 14,56

1/6

4100 1356: Ø280mm

€: 18,85 / IVA: 22,81

1/6

4100 1352: Ø200mm

€: 13,30 / IVA: 16,10

1/6

4100 1357: Ø300mm

€: 20,76 / IVA: 25,11

1/6

4100 1353: Ø220mm

€: 14,32 / IVA: 17,33

1/6

4100 1358: Ø320mm

€: 21,56 / IVA: 26,08

1/6

4100 1354: Ø240mm

€: 15,46 / IVA: 18,70

1/6

4100 1359: Ø340mm

€: 25,94 / IVA: 31,38

1/6

4100 1355: Ø260mm

€: 17,95 / IVA: 21,72

1/6



COCINA / CUISINE / KITCHEN / CUCINA / COZINHA

Sartenes y Ollas / Poêles et Casseroles / Frying Pans and Pots / Tegami e Pentole / Frigideiras e Panelas



Polenta

Mod. Polenta

Cacerolas, ollas y sartenes de acero inoxidable 18/10 con un espesor de 0,7 mm y tapa de cristal resistente. Adecuado a todos los tipos de fuentes de calor: gas, electricidad, cerámica e inducción. Con tapas en cristal resistente y fondo encapsulado de tres capas inferiores compuesto de aluminio. El disco encapsulado de acero inoxidable asegura una perfecta y uniforme disipación del calor, resistente hasta 500°C de temperatura.

Casserolles, marmites et poêles en acier inoxydable 18/10, avec une épaisseur de 0,7 mm et un couvercle en cristal résistant, approprié à tous les types de sources de chaleur à gaz, électricité, céramique et induction. Avec couvercles en cristal résistant et un fond encapsulé de trois couches inférieures composé d'aluminium. Le disque encapsulé d'acier inoxydable assure une dissipation uniforme et parfaite de la chaleur, résistante jusqu'à 500°C.

18/10 Stainless steel cooking pots, pans and saucepans, 0.7 mm thick, resistant glass lid, suitable for all type of sources of heat: gas, electricity, ceramic and induction. They have resistant glass lids and an aluminium three-ply encapsulated bottom. The encapsulated stainless steel disc guarantees a perfect and uniform heat dissipation, resistant up to 500°C.

Casseruole, pentole e padelle in acciaio inox 18/10 con uno spessore da 0,7mm e coperchio in vetro resistente e con fondo incapsulato a tre strati in alluminio, adatte a tutti i tipi di cottura: gas, elettrico, ceramica e induzione. Il disco incapsulato in acciaio inox assicura una perfetta e uniforme dissipazione del calore, resiste fino a una temperatura di 500°C.

Caçarolas, panelas e sertãs de aço inoxidável 18/10 com uma espessura de 0,7 mm e tampa de vidro resistente, adequadas para todos os tipos de fontes de calor de gás, elétrico, cerâmica e indução. Tampa de vidro resistente e fundo encapsulados de três camadas inferiores composto de alumínio. O disco de aço inoxidável encapsulado, garante a perfeita e uniforme dissipação de calor, resistente até uma temperatura de 500°C.



COCINA / CUISINE / KITCHEN / CUCINA / COZINHA

Sartenes y Ollas / Poêles et Casseroles / Frying Pans and Pots / Tegami e Pentole / Frigideiras e Panelas

Mod. Polenta



SARTÉN ANTIADHERENTE INOXIDABLE DE INDUCCIÓN
POÊLE ANTIADHÉSIF INOX INDUCTION
ST.STEEL INDUCTION SAUCEPAN NON-STICK
PADELLA INOX A INDUZIONE ANTIADERENTE
FRIGIDEIRA INOX INDUÇÃO ANTIADERENTE

4100 1523: Ø180mm
€: 21,60 / IVA: 26,14



4100 1525: Ø220mm
€: 26,40 / IVA: 31,95



4100 1524: Ø200mm
€: 22,80 / IVA: 27,59



4100 1526: Ø240mm
€: 28,80 / IVA: 34,85



CACEROLA INOX CON MANGO DE INDUCCIÓN
CASSEROLE MANCHE INOX INDUCTION
ST.STEEL INDUCTION PAN
CASSERUOLA MANICO INOX A INDUZIONE
ÇAÇAROLA COM CABO INOX INDUÇÃO

4100 1532: Ø160mm
€: 12,60 / IVA: 15,25



4100 1534: Ø200mm
€: 16,80 / IVA: 20,33



4100 1533: Ø180mm
€: 15,40 / IVA: 18,64



Mod. Pclenta

CACEROLA INOX DE INDUCCIÓN CON TAPA DE VIDRIO
 CASSEROLES INOX INDUCTION
 ST.STEEL INDUCTION PAN
 CASSERUOLA INOX A INDUZIONE
 CAÇAROLA INOX INDUÇAO

4100 1502: Ø160mm
 €: 19,04 / IVA: 23,03
 1

4100 1505: Ø220mm
 €: 28,92 / IVA: 34,99
 1

4100 1503: Ø180mm
 €: 22,18 / IVA: 26,84
 1

4100 1506: Ø240mm
 €: 31,65 / IVA: 38,30
 1

4100 1504: Ø200mm
 €: 24,95 / IVA: 30,18
 1

4100 1507: Ø260mm
 €: 37,17 / IVA: 44,98
 1



OLLA INOX DE INDUCCIÓN CON TAPA DE VIDRIO
 MARMITE INOX INDUCTION
 ST.STEEL INDUCTION POT
 PENTOLA INOX A INDUZIONE
 PANELA INOX INDUÇAO

4100 1512: Ø160mm
 €: 20,01 / IVA: 24,22
 1

4100 1515: Ø220mm
 €: 30,73 / IVA: 37,19
 1

4100 1513: Ø180mm
 €: 23,68 / IVA: 28,65
 1

4100 1516: Ø240mm
 €: 35,26 / IVA: 42,66
 1

4100 1514: Ø200mm
 €: 26,51 / IVA: 32,08
 1

4100 1517: Ø260mm
 €: 42,18 / IVA: 51,04
 1





Polenta

Mod. Polenta

Ollas a presión tradicional de acero inoxidable 18/10, con espesor de 1,2 mm, asas y pomo de baquelita y junta de cierre en silicona. Dispone de fondo termodifusor en Acero Inoxidable y Aluminio. Contiene tres dispositivos de seguridad y es válida para todo tipo de cocinas: gas, electricidad, halógena, vitrocerámica y especialmente inducción.

Cocottes-minutes traditionnelle en acier inoxydable 18/10. Avec épaisseur de 1,2 mm, anses et pommeau en bakélite assemblée d'une fermeture de silicone. elle dispose d'un fond thermodiff usseur en acier Inoxydable et Aluminium. Elle contient trois dispositifs de sécurité et est destinée pour toute sorte de cuisson: gaz, électricité, halogène, vitro-céramique et spécialement à l'induction.

Traditional 18/10 stainless steel pressure cooker, 1,2 mm thick, with Bakelite handles and knob, and a silicone sealing ring. It has a stainless steel and aluminium thermodiff user bottom and three safety devices. It is acceptable for all type of hobs: gas, electric, halogen, ceramic, and especially induction.

Pentole a pressione tradizionali, in acciaio inox 18/10 con spessore di 1,2mm con manici e pomello in bachelite e guarnizione di tenuta in silicone. Dispone di fondo in Acciaio Inox e Alluminio. Contiene tre dispositivi di sicurezza ed è valida per tutti i tipi di cucina: gas, elettrica, alogena, vetroceramica e ad induzione.

Panelas de pressão tradicionais de aço inoxidável 18/10, com espessura de 1,2 mm, com pegas e alça de baquelite e a junta de vedação em silicone. O fundo é de termo difusão em aço inoxidável e alumínio. Contém três dispositivos de segurança e é válida para todos os tipos de fogões: gás, eletricidade, halogéneo, cerâmica e, especialmente, indução.

Mod. Polenta

OLLA PRESIÓN INOX DE INDUCCIÓN
 AUTOUISEUR INOX
 INOX PRESSURE COOKER
 PENTOLA A PRESSIONE INOX
 PANELA DE PRESSÃO INOX



4100 1586: 4,5 l
 €: 48,30 / IVA: 58,44
 1

4100 1588: 8 l
 €: 52,50 / IVA: 63,53
 1

4100 1587: 6 l
 €: 50,45 / IVA: 61,04
 1

4100 1589: 10 l
 €: 62,90 / IVA: 76,11
 1

CE 0464



COCINA / CUISINE / KITCHEN / CUCINA / COZINHA

Sartenes y Ollas / Poêles et Casseroles / Frying Pans and Pots / Tegami e Pentole / Frigideiras e Panelas



Mod. Modena

Ollas rápidas de acero inoxidable 18/10 con espesor de 1,2mm, con válvula de seguridad e indicador de presión de 3 niveles. Dispone de fondo termodifusor de acero inoxidable y aluminio y es válida para todo tipo de cocinas: gas, electricidad, halógena, vitrocerámica y especialmente inducción.

Cuiseur rapide en acier inoxydable 18/10 avec épaisseur de 1,2mm, avec valve sécurité et indicateur de pression de 3 niveaux. Dispose d'un fond thermo en acier inoxydable et aluminium et est approprié pour tout type de cuisines: gaz, électricité, halogène, vitrocéramique et spécialement induction.

18/10 stainless steel pressure cookers, 1,2 mm thick, with safety valve and a 3-level pressure indicator. It has a stainless steel and aluminium thermodiffuser bottom and it is suitable for any kind of hobs: gas, electric, halogen, ceramic, and especially induction.

Pentole a pressione in acciaio inox 18/10 con spessore da 1,2mm; dotate di valvola di sicurezza e indicatore di pressione di 3 livelli. Dispongono di fondo termo diffusore in acciaio inox e alluminio. Progettate per qualsiasi tipo di cucina: gas, elettrica, alogena, vetroceramica e soprattutto induzione.

Panelas rápidas de aço inoxidável 18/10 com 1,2 mm de espessura, com válvula de segurança e indicador de pressão de 3 níveis. Tem fundo termo difusor de aço inoxidável e alumínio e é válido para todos os tipos de fogões: gás, eletricidade, halogéneo, cerâmica e especialmente indução.

Modena

Mod. Módena Mini

OLLA RÁPIDA INDUCCIÓN
 CUISEUR RAPIDE INDUCTION
 INDUCTION PRESSURE COOKER
 PENTOLA A PRESSIONE, INDUZIONE
 PANELA RÁPIDA DE INDUÇÃO

Mod. Módena

OLLA RÁPIDA INDUCCIÓN
 CUISEUR RAPIDE INDUCTION
 INDUCTION PRESSURE COOKER
 PENTOLA A PRESSIONE, INDUZIONE
 PANELA RÁPIDA DE INDUÇÃO



4100 1596: 2 l
 €: 41,38 / IVA: 50,06
 1

4100 1597: 3 l
 €: 43,56 / IVA: 52,70
 1

4100 1593: 4 l
 €: 50,15 / IVA: 60,67
 1

4100 1594: 6 l
 €: 54,43 / IVA: 65,87
 1

4100 1595: 8 l
 €: 58,80 / IVA: 71,14
 1

CE 0464



COCINA / CUISINE / KITCHEN / CUCINA / COZINHA

Paelleras / Poêles à paella / Paella pans / Padelle per Paella / Paelheira



La paellera de acero pulido es la que se usa tradicionalmente para hacer la paella valenciana.

La poêle à paella en acier poli est celle qui est traditionnellement utilisée pour faire la paella Valenciana.

Paella pan made of polished steel is traditionally used for cooking the Valencian paella.

Padella in acciaio lucido, utilizzata tradizionalmente per cucinare la paella valenciana.

A paelheira de aço polido é a usada tradicionalmente para fazer a paelha valenciana.



PAELLERA ACERO PULIDA
PLAT À PAELLA ACIER POLIE
POLISHED STEEL PAELLA PAN
PADELLA PER PAELLA IN FERRO LUCIDATA
PAELHEIRA AÇO POLIDA

4100 7123: Ø260mm

€: 2,92 / IVA: 3,53

📦 1/6 2 🍷

4100 7129: Ø380mm

€: 5,20 / IVA: 6,30

📦 1/6 8 🍷

4100 7133: Ø500mm

€: 8,60 / IVA: 10,41

📦 1/4 13 🍷

4100 7125: Ø300mm

€: 3,45 / IVA: 4,18

📦 1/6 4 🍷

4100 7131: Ø420mm

€: 6,35 / IVA: 7,69

📦 1/6 10 🍷

4100 7135: Ø600mm

€: 15,50 / IVA: 18,76

📦 1/4 20 🍷

4100 7127: Ø340mm

€: 4,10 / IVA: 4,97

📦 1/6 6 🍷

4100 7132: Ø460mm

€: 7,25 / IVA: 8,78

📦 1/4 12 🍷

4100 7137: Ø700mm

€: 29,55 / IVA: 35,76

📦 1/2 30 🍷



PAELLERA ACERO PULIDA (4 ASAS)
PLAT À PAELLA ACIER POLIE (4 ANSES)
POLISHED STEEL PAELLA PAN (4 HANDLES)
PADELLA PER PAELLA IN FERRO LUCIDATA (4 ASAS)
PAELHEIRA AÇO POLIDA (4 ASAS)

4100 7138: Ø800mm

€: 39,90 / IVA: 48,28

📦 1 40 🍷

4100 7139: Ø900mm

€: 52,95 / IVA: 64,07

📦 1 50 🍷

4100 7141: Ø1150mm

€: 146,50 / IVA: 177,27

📦 1 120 🍷



COCINA / CUISINE / KITCHEN / CUCINA / COZINHA

Paelleras / Poêles à paella / Paella pans / Padelle per Paella / Paelheira

La paellera de acero esmaltado tiene el mismo uso, pero su limpieza y mantenimiento son más sencillos.

La poêle à paella en acier émaillé a la même utilisation, mais nettoyage et entretien sont plus simples.

Paella pan made of enamelled steel is also used for cooking the Valencian paella, but its cleaning and maintenance is easier.

La padella in acciaio smaltato ha lo stesso utilizzo ma a differenza di quella lucida ha una pulizia e una manutenzione più semplice.

A paelheira de aço esmaltado tem a mesma utilização, mas a sua limpeza e manutenção são mais fáceis.



PAELLERA ACERO ESMALTADA PLAT À PAELLA ACIER VITRÉ ENAMELLED STEEL PAELLA PAN PADELLA PER PAELLA IN FERRO SMALTATO PAELHEIRA AÇO VIDROS

4100 7531: Ø100mm
€: 2,10 / IVA: 2,54
1/10 mini

4100 7538: Ø300mm
€: 5,10 / IVA: 6,18
1/6 4

4100 7545: Ø460mm
€: 11,40 / IVA: 13,80
1/4 12

4100 7533: Ø150mm
€: 2,55 / IVA: 3,09
1/10 mini

4100 7540: Ø340mm
€: 6,30 / IVA: 7,63
1/6 6

4100 7546: Ø500mm
€: 13,30 / IVA: 16,10
1/4 13

4100 7534: Ø200mm
€: 3,25 / IVA: 3,94
1/6 mini

4100 7542: Ø380mm
€: 7,80 / IVA: 9,44
1/6 8

4100 7548: Ø600mm
€: 21,20 / IVA: 25,66
1/4 20

4100 7536: Ø260mm
€: 4,20 / IVA: 5,09
1/6 2

4100 7544: Ø420mm
€: 9,60 / IVA: 11,62
1/6 10

4100 7550: Ø700mm
€: 41,00 / IVA: 49,61
1/2 30

PAELLERA ACERO ESMALTADA (4 ASAS) PLAT À PAELLA ACIER VITRÉ (4 ANSES) ENAMELLED STEEL PAELLA PAN (4 HANDLES) PADELLA PER PAELLA IN FERRO SMALTATO (4 ASAS) PAELHEIRA AÇO VIDROS (4 ASAS)

4100 7551: Ø800mm
€: 55,70 / IVA: 67,40
1 40

4100 7552: Ø900mm
€: 73,70 / IVA: 89,18
1 50

4100 7554: Ø1150mm
€: 198,20 / IVA: 239,84
1 120



Paellera especial para placas de inducción y vitrocerámica.

Poêle à paella spéciale plaques à induction et vitrocéramiques.

Special paella pan for induction and glass-ceramic hob.

Pentola speciale per le cucine a induzione e vetroceramica.

Paelheira especial para placas de indução e vitrocerâmica.



PAELLERA ACERO PULIDA INDUCCIÓN
PLAT À PAELLA ACIER POLIE INDUCTION
POLISHED STEEL PAELLA PAN INDUCTION
PADELLA PER PAELLA IN FERRO LUCIDATA INDUZIONE
PAELHEIRA AÇO POLIDA INDUÇÃO

4100 7612: Ø320mm

€: 10,01 / IVA: 12,12

1/6 5

4100 7614: Ø360mm

€: 13,73 / IVA: 16,62

1/6 7



PAELLERA ACERO ESMALTADO INDUCCIÓN
POÊLE À PAELLA ACIER ÉMAILLÉ INDUCTION
ENAMELLED STEEL PAELLA PAN INDUCTION
TEGAME SMALTATO A INDUZIONE PER PAELLA
PAELHEIRA AÇO ESMALTADO INDUÇÃO

4100 7621: Ø300mm

€: 12,03 / IVA: 14,55

1/6 4

4100 7623: Ø340mm

€: 14,56 / IVA: 17,62

1/6 6



COCINA / CUISINE / KITCHEN / CUCINA / COZINHA

Paelleras / Poêles à paella / Paella pans / Padelle per Paella / Paelheira

Plancha Grill antiadherente para inducción. Cuerpo en aluminio inyectado.

Iron Grill antiadhésive induction. Corps en aluminium injecté.

Grill pan with non-stick induction. Sturdy injected aluminium body.

Iron Grill antiaderenti induzione. Corpo in alluminio iniettato.

Tabuleiro Grelhador anti-aderente com indução. Corpo em alumínio injetado.

Sartén tradicional sin borde, fabricada con grosor extra. Perfecta para elaborar platos de cocina tradicionales.

Poêle traditionnelle sans bord, fabriquée avec épaisseur supplémentaire. Parfaite pour cuisiner des plats de cuisine traditionnelles.

Traditional frying pan without edge and extra thickness. Perfect to prepare traditional Spanish plates.

Tegame tradizionale senza bordo, fabbricato con uno spessore supplementare. Perfetto per cucinare tutti i piatti della cucina tradizionale.

Frigideira tradicional sem bordas, fabricada com uma espessura extra. Perfeita para cozinhar pratos tradicionais.

Se usa para guisar todo tipo de arroces melosos y calderetas.

Utilisée pour cuire tout type de riz moelleux et plats et sauce.

It is used for cooking of any smooth rice or lamb stews.

Utilizzato per cucinare tutti i tipi di risotti cremosi e gli stufati.

Utiliza-se para cozinhar todo o tipo de arroz com caldo e guisados.



PLANCHA GRILL BANDEJA INDUCCIÓN
PLANCHA GRILL PLATEAU INDUCTION
INDUCTION GRIDDLE
VASSOIO GRILL PER INDUZIONE
GRELHADOR INDUÇÃO

4100 8010: 330x220 mm

€: 24,10 / IVA: 29,16

1/6

4100 8011: 400x280 cm

€: 28,92 / IVA: 34,99

1/6



SARTÉN LIONESA DE ACERO CON ASAS
POÊLE ACIER AVEC ANSES
STEEL FRYPAN W/HANDLES
PADELLA IN FERRO C/ASAS
SERTÁ AÇO COM ASAS

4100 7823: Ø360mm

€: 13,74 / IVA: 16,63

1/4

4100 7826: Ø500mm

€: 24,95 / IVA: 30,19

1/3

4100 7824: Ø400mm

€: 17,09 / IVA: 20,69

1/4



SARTÉN HONDA ESMALTADA CON ASAS
POÊLE À MANCHE VITRÉ AVEC ANSES "HONDA"
ENAMELLED DEEP FRYPAN W/HANDLES "HONDA"
PADELLA PROFONDA SMALTATO C/ASAS "HONDA"
SERTÁ FUNDA VIDRIOS COM ASAS "HONDA"

4100 7808: Ø280mm

€: 5,22 / IVA: 6,32

1/6

4100 7814: Ø400mm

€: 10,32 / IVA: 12,49

1/4

4100 7810: Ø320mm

€: 6,49 / IVA: 7,86

1/4

4100 7815: Ø450mm

€: 15,50 / IVA: 18,76

1/3

4100 7812: Ø360mm

€: 8,25 / IVA: 9,99

1/4

Sartén con mango sin borde. Perfecta para saltear alimentos. Fabricada con grosor extra.

Poêle avec manche sans bord. Parfaite pour faire revenir des aliments. Fabriquée avec épaisseur supplémentaire.

Frying pan with handle without edge and extra thickness. Perfect to fry any food.

Tegame con manico senza bordo. Perfetto per soff riggere gli alimenti. Fabricato con un spessore supplementare.

Frigideira com cabo sem borda. Perfeita para saltear os alimentos. Fabricada com uma espessura extra.



**SARTÉN LIONESA ACERO CON MANGO
POÊLE ACIER AVEC ANSES "LIONESA"
STEEL FRYPAN W/HANDLES "LIONESA"
PADELLA IN FERRO C/ASAS "LIONESA"
SERTÃ AÇO COM ASAS "LIONESA"**

4100 7832: Ø320mm

€: 12,30 / IVA: 14,88

1/6

Sartén con mango y asa sin borde. Perfecta para saltear alimentos. Fabricada con grosor extra.

Poêle avec manche et poignée sans bord. Parfaite pour faire revenir des aliments.

Fabriquée avec épaisseur supplémentaire. Frying pan with handles and without edge and extra thickness. Perfect to fry any food.

Tegame senza bordo con manico e impugnatura. Perfetto per soff riggere gli alimenti. Fabricato con uno spessore supplementare.

Frigideira com cabo e pega sem borda. Perfeita para saltear os alimentos. Fabricada com uma espessura extra.



**SARTÉN LIONESA CON MANGO Y ASA
POÊLE ACIER AVEC ANSES "LIONESA"
FRYING PAN WITH TWO TYPES OF HANDLE
PADELLA IN FERRO C/ASAS "LIONESA"
SERTÃ AÇO COM ASAS "LIONESA"**

4100 7833: Ø400mm

€: 17,43 / IVA: 21,10

1/4

Trébedes de forja redondas para cocinar con leña. Permite situar sartenes y paelleras sobre llamas o brasas.

Trépied en forge rond pour cuisiner sur feu de bois. Permet de poser des grandes poêles et poêles à paella sur les flammes ou sur les braises.

Round wrought iron trivet to cook with firewood. It allows the placement of saucepans and paella pans above flames or embers.

Sottopentola tondo forgiato, per cottura a legna. Consente la cottura in pentole e padelle su fuoco vivo o brace.

Tripé de forja redondo para cozinhar com lenha. Permite colocar as sertãs e as paelheiras sobre as chamas ou brasas



**TRÉBEDE DE FORJA REDONDA
DESSOUS ROND EN FER FORGÉ
ROUND WROUGHT IRON TRIVET
SOTTOPENTOLA ROTONDO IN FERRO BATTUTO
TREMPE DE FERRO REDONDO**

4100 7842: Ø350mm

€: 11,24 / IVA: 13,61

1

4100 7845: Ø500mm

€: 26,47 / IVA: 32,03

1



COCINA / CUISINE / KITCHEN / CUCINA / COZINHA

Paelleras / Poêles à paella / Paella pans / Padelle per Paella / Paelheira



Patas de soporte cuadradas + paellera 460 mm + quemador 400 mm. Presentado en caja-estuche cómodo de transportar.

Pieds de support carrés + poêle à paella 46 cm + brûleur 40 cm Présentés en boîte de rangement pratique pour le transport.

Square support feet + Paella pan 46cm + burner 40 cm. Packed in a comfortable box for transport.

Supporto quadrato gambe + padella 46cm + fornello 40cm. Riposto in un contenitore facile da trasportare.

Patas de suporte quadradas + paelheira 46 cm + fogareiro 40 cm. Apresentado em caixa-estôjo cómodo para transportar.

KIT PAELLERA 460mm + QUEMADOR 400mm + PATAS + TRÍPODE
KIT POUR PAELLA - PLAT 460mm + BRÛLEUR 400mm + TRÉPIED
KIT PAELLA - PAN 460mm + BURNER 400mm + SUPPORT LEGS
KIT PER PAELLA - PADELLA 460mm + BRUCIATORE 400mm + FORNELLI
KIT PAELLA - PAELHEIRA 460mm + QUEIMADOR 400mm + TRIPÉ



CE

4100 7750:
 €: 45,95 / IVA: 55,60

1



COCINA / CUISINE / KITCHEN / CUCINA / COZINHA

Paelleras / Poêles à paella / Paella pans / Padelle per Paella / Paelheira

Los quemadores a gas se utilizan como difusores de fuego. Los hay de diferentes diámetros y aros. Proporcionan un fuego uniforme bajo la paellera, sartén o cualquier recipiente de cocina.

Les brûleurs à gaz, sont utilisés comme diffuseurs de feu ; ils sont de différents diamètres et de différents cerclages. Ils fournissent un feu uniforme sous la poêle à paella, ou tout autre récipient de cuisine.

The gas burners are used as diffusers of fire; there are different diameters and rings. They provide you with a uniform fire under your paella or frying pan.

I fornelli a gas sono utilizzati come diffusori di calore; ci sono di diversi diametri e piastre. Forniscono un calore uniforme alla superficie del recipiente da cucina utilizzato.

Os fogareiros a gás, são utilizados como difusores de fogo; existem de diferentes diâmetros e anéis. Fornecem um fogo uniforme sob a panela, frigideira ou qualquer outro recipiente de cozinha.

KIT PAELLERA Ø420mm + QUEMADOR Ø400mm
KIT POUR PAELLA - PLAT Ø420mm + BRÛLEUR Ø400mm
KIT PAELLA - PAN Ø420mm + BURNER Ø400mm
KIT PER PAELLA - PADELLA Ø420mm + BRUCIATORE Ø400mm
KIT PAELLA - PAELHEIRA Ø420mm + QUEIMADOR Ø400mm



CE

4100 7755:
€: 32,63 / IVA: 39,49

1

QUEMADOR PAELLERO A GAS
BRÛLEUR À GAZ POUR PAELLA
PAELLA GAS BURNER
BRUCIATORE DI GAS PER PAELLA
PAELLA QUEIMADOR DE GÁS



CE

4100 7704: Ø400mm
€: 27,10 / IVA: 32,80

1

4100 7705: Ø500mm
€: 33,50 / IVA: 40,51

1



**TUBO FLEXIBLE 1,5m PARA GAS BUTANO + ABRAZADERAS
RECHARGE BRÛLEUR TUBE + CAOUTCHOUC + COLLIER
SPARE REGULATOR + TUBE + TUBE TIE
RICAMBI BRUCIATORE TUBO + GOMMA + FASCETTE
REPOSIÇÃO QUEIMADOR TUBO + BORRACHA + ABRAÇADEIRA**

CE

AENOR
Producto
Certificado



4100 7761:
€: 3,20 / IVA: 3,88

1

**REGULADOR DE GAS BUTANO
DÉTENDEUR DE GAZ BUTANE
GAS REGULATOR
REGOLATORE DI GAS BUTANO
GÁS REGULADOR BUTANO**



CE

4100 7762: 28 mbar
€: 8,48 / IVA: 10,27

1

4100 7763: 50 mbar
€: 11,07 / IVA: 13,39

1

Tubo flexible 1,5 m para gas butano + abrazaderas y reguladores de gas butano para adaptar el quemador a la botella de gas.

Tube flexible 1,5 m pour gaz butane + colliers. Régulateurs de gaz butane pour adapter le brûleur à la bouteille de gaz.

1,5m long fl exible tube 1,5m for Butane gas + hose clamps. Butane gas regulators to fi t the burners to the gas cylinders.

Tubo fl essibile da 1,5m per gas butano + fascette. Regolatori di gas butano per adattare il fornello alla bombola del gas.

Tubo fl exível 1,5m para gás butano + braçadeiras. Reguladores de gás butano para adaptar o fogareiro à garrafa do gás.

COCINA / CUISINE / KITCHEN / CUCINA / COZINHA

Utensilios / Ustensiles / Kitchen utensils / Utensili / Utensílios



Valentia

Mod. Valentia

Utensilios de cocina fabricados en Acero Inoxidable y Nylon, diseñados para no rayar los antiadherentes habituales de los recipientes de cocina. Su sistema anti-rayado permite usarlo en cualquier superficie con antiadherentes y superficies delicadas. Con una zona de silicona para una mejor sujeción, combinan las propiedades duraderas del acero inoxidable con la inocuidad del nylon. Todas las unidades cuentan con certificado alimentario.

Ustensiles de cuisine fabriqués en Acier Inoxydable et Nylon, conçus pour ne pas rayer le revêtement antiadhésif des récipients de cuisine. Le système anti-rayure permet une utilisation sur toute surface disposant d'un revêtement antiadhésif et surfaces sensibles. Tous les ustensiles ont un manche conçu avec du silicone permettant une meilleure prise. Associent une longue durée de vie grâce à l'acier inoxydable à l'innocuité du nylon. Tous les ustensiles disposent d'un certifi cat alimentaire.

Kitchen utensils completely manufactured in stainless steel and nylon, designed to avoid scratching the non-stick coating of the pans. Their antiscratch system allows their use on any non-stick and delicate surfaces. All utensils have a handle with a silicone area for a better grip. In addition, they combine the long-lasting properties of the stainless steel with the harmlessness of the nylon. All units have a food certifi cate.

Utensili da cucina fabbricati in acciaio inox e nylon, sono progettati per evitare il danneggiamento (graffi) tipici dei recipienti da cucina. Il suo sistema anti-graffi o consente l'utilizzo su qualsiasi superfi cie antiaderente e su superfi ci delicate. Tutti gli utensili dispongono di un manico in silicone per una migliore aderenza, combinando le proprietà durevoli dell'acciaio inox con la sicurezza del nylon. Tutte le unità dispongono di un certifi cato alimentare.

Utensílios de cozinha fabricados em aço inoxidável e nylon, foram desenhados para evitar riscar os antiaderentes habituais dos recipientes da cozinha. Seu sistema anti-scratch permite o uso em qualquer superfície com antiaderentes e superfícies delicadas. Todos os utensílios têm um cabo com uma zona de silicone para melhor aderência. Além disso combinam as propriedades de durabilidade do aço inoxidável, com a segurança do nylon. Todas as unidades possuem certifi cado de alimentos.



Mod. Valentia

CACILLO NYLON-INOX
LOUCHE NYLON-INOX
NYLON-ST.STEEL LADLE
MESTOLO NYLON-INOX
CONCHA NYLON-INOX

4100 1601:
€: 1,98 / IVA: 2,40

1/12



CAZO DE PASTA NYLON-INOX
CUILLÈRE À SPAGHETTIS NYLON-INOX
NYLON-ST.STEEL PASTA SERVING SPOON
SPAGHETTI CUCCHIAIO NYLON-INOX
COLHER DE ESPARGUETE NYLON-INOX

4100 1603:
€: 1,98 / IVA: 2,40

1/12



ESPÁTULA NYLON-INOX
SPATULE NYLON-INOX
NYLON-ST.STEEL TURNER
SPATOLA NYLON-INOX
ESPÁTULA NYLON-INOX

4100 1605:
€: 2,05 / IVA: 2,49

1/12



ESPÁTULA GRANDE NYLON-INOX
SPATULE MAXI NYLON-INOX
NYLON-ST.STEEL MAXI TURNER
SPATOLA GRANDE NYLON-INOX
ESPÁTULA MAXI NYLON-INOX

4100 1607:
€: 1,98 / IVA: 2,40

1/12



ESPUMADERA NYLON-INOX
ÉCUMOIRE NYLON-INOX
NYLON-ST.STEEL SKIMMER
MESTOLO NYLON-INOX
ESCUMADEIRA NYLON-INOX

4100 1602:
€: 1,98 / IVA: 2,40

1/12



CUCHARA GRANDE NYLON-INOX
GRANDE CUILLÈRE NYLON/INOX
NYLON/ST.STEEL LARGE SPOON
CUCCHIAIO GRANDE NYLON/INOX
COLHER GRANDE NYLON/INOX

4100 1604:
€: 1,98 / IVA: 2,40

1/12



TENEDOR NYLON-INOX
FOURCHETTE NYLON-INOX
NYLON-ST.STEEL FORK
FORCHETTE NYLON-INOX
GARFO NYLON-INOX

4100 1606:
€: 1,98 / IVA: 2,40

1/12



ESPÁTULA REPOSTERÍA NYLON-INOX
SPATULE DE PÂTISSERIE NYLON-INOX
NYLON-ST.STEEL CAKE SERVER
SPATOLA PASTICCERIA NYLON-INOX
ESPÁTULA P/BOLO NYLON-INOX

4100 1608:
€: 2,21 / IVA: 2,68

1/12



COCINA / CUISINE / KITCHEN / CUCINA / COZINHA

Utensilios / Ustensiles / Kitchen utensils / Utensili / Utensílios



Gravina

Mod. Gravina

CACILLO INOX
LOUCHE INOX
ST.STEEL LADLE
MESTOLO INOX
CONCHA INOX

4100 1611:
€: 2,66 / IVA: 3,22

📦 1/12



ESPUMADERA INOX
ÉCUMOIRE INOX
ST.STEEL SKIMMER
MESTOLO INOX
ESCUMADEIRA INOX

4100 1612:
€: 2,62 / IVA: 3,18

📦 1/12



CAZO DE PASTA INOX
CUILLÈRE À SPAGHETTIS INOX
ST.STEEL PASTA SERVING SPOON
SPAGHETTI CUCCHIAIO INOX
COLHER DE ESPARGUETE INOX

4100 1613:
€: 2,54 / IVA: 3,08

1/12



CUCHARA GRANDE INOX
CUILLÈRE INOX
ST.STEEL LARGE SPOON
CUCCHIAIO GRANDE INOX
COLHER GRANDE INOX

4100 1614:
€: 2,54 / IVA: 3,08

1/12



Mod. Gravina

Utensilios de cocina fabricados completamente en Acero Inoxidable, fáciles de limpiar, aptos para el lavavajillas de larga duración y resistentes al paso del tiempo. Los mangos contienen una zona de silicona para una mejor sujeción. Todas las unidades cuentan con certificado alimentario.

Ustensiles de cuisine fabriqués en Acier Inoxydable facile à nettoyer, apte pour le lave-vaisselle, longue durée de vie. Les manches sont conçus avec une partie en silicone pour une meilleure prise. Tous les ustensiles disposent d'un certifi cat alimentaire.

Kitchen utensils completely manufactured in an easy-to clean Stainless Steel, suitable for dishwashers, long-lasting durability. Handles have a silicone area for a better grip. All units have a food certifi cate.

Utensili da cucina fabbricati totalmente in Acciaio Inox di facile pulizia. Adatti per la lavastoviglie, di lunga durata e resistenti nel tempo. I manici dispongono di una zona in silicone per una migliore aderenza. Tutte le unità dispongono di un certifi cato alimentare.

Utensilios de cozinha totalmente fabricado em Aço Inoxidável fácil de limpar, laváveis na máquina da louça, longa duração e resistência ao longo do tempo. Os cabos contêm uma zona de silicone para melhor aderência. Todas as unidades possuem certifi cado de alimentos.

COCINA / CUISINE / KITCHEN / CUCINA / COZINHA

Utensilios / Ustensiles / Kitchen utensils / Utensili / Utensílios

Mod. Gravina



CUCHARA PERFORADA INOX
CUILLÈRE PERFORÉ INOX
ST.STEEL PERFORATED SPOON
CUCCHIAIO PERFORATO INOX
COLHER PERFURADA INOX

4100 1616:
€: 2,54 / IVA: 3,08

1/12



ESPÁTULA TARTAS INOX
SPATULE INOX
ST.STEEL SCRAPER
SPATOLA DOLCI INOX
ESPÁTULA INOX

4100 1645:
€: 2,04 / IVA: 2,46

1/12



ESPÁTULA INOX
SPATULE INOX
ST.STEEL TURNER
SPATOLA INOX
ESPÁTULA INOX

4100 1615:
€: 2,62 / IVA: 3,18

1/12



PRENSA PATATAS INOX
PRESSE PURÉE INOX
ST.STEEL POTATOE MASHER
STAMPA SCHIACCIAPATATE INOX
ESMAGADOR DE BATATA INOX

4100 1632:
€: 3,50 / IVA: 4,24

1/12



RALLADOR LIMÓN INOX
RÂPE CITRON INOX
ST.STEEL LEMON GRATER
GRATTUGIA INOX
RASPADOR DE LIMÃO INOX

4100 1631:
€: 1,66 / IVA: 2,01

1/12



Mod. Gravina

PRENSA-AJOS INOX
PRESSE-AIL INOX
ST.STEEL GARLIC PRESSER
STAMPA DI AGLIO INOX
ESPREMEDOR DE ALHOS INOX

4100 1633:
€: 4,36 / IVA: 5,28

📦 1/12



ABRELATAS INOX
OUVRE-BOÎTES INOX
ST.STEEL CAN OPENER
APRI DI LATTA INOX
ABRE-LATAS INOX

4100 1635:
€: 4,45 / IVA: 5,39

📦 1/12



DESCORAZONADOR INOX
EPLUCHEUR INOX
ST.STEEL FRUIT CORER
LEVATORSOLO INOX
CORTADOR INOX

4100 1636:
€: 1,47 / IVA: 1,78

📦 1/12



DESCAPSULADOR INOX
DÉCAPSULEUR INOX
ST.STEEL BOTTLE OPENER
APRIBOTTIGLIE INOX
DESCAPSULADOR INOX

4100 1634:
€: 1,43 / IVA: 1,74

📦 1/12



VACIADOR INOX
CUILLÈRE BOULE PARISIENNE INOX
ST.STEEL FRUIT BALLER
FRUTTA BALLER INOX
ENFORMADOR DE MELÃO

4100 1637:
€: 1,93 / IVA: 2,34

📦 1/12



RACIONADOR HELADO INOX
CUILLÈRE À BOULE DE GLACE INOX
ST.STEEL ICE CREAM SCOOP
GELATO SCOOP INOX
COLHER DE GELADO INOX

4100 1638:
€: 1,93 / IVA: 2,34

📦 1/12



COCINA / CUISINE / KITCHEN / CUCINA / COZINHA

Utensilios / Ustensiles / Kitchen utensils / Utensili / Utensílios



Gravina

Mod. Gravina

PELADOR PATATAS INOX
ÉPLUCHEUR DE LÉGUMES INOX
ST.STEEL POTATO PEELER
PELAPATATE INOX
DESCASCADOR LEGUMES INOX

4100 1639:

€: 2,09 / IVA: 2,53

1/12



PELADOR VERTICAL INOX
ÉPLUCHEUR DE LÉGUMES INOX
ST.STEEL VERTICAL POTATO PEELER
PELAPATATE VERTICALE INOX
DESCASCADOR DE LEGUMES LÂMINA VERTICAL INOX

4100 1640:

€: 1,99 / IVA: 2,41

1/12



Mod. Gravina

PELADOR INOX
ÉPLUCHEUR DE LÉGUMES INOX
ST.STEEL PEELER
PELAPATATE INOX
DESCASCADOR TRADICIONAL INOX

4100 1641:
€: 1,66 / IVA: 2,01

📦 1/12



CORTADOR QUESO INOX
COUPE-FROMAGE INOX
ST.STEEL CHEESE SLICER
TAGLIERINA DI FORMAGGIO INOX
CORTADOR DE QUEIJO INOX

4100 1642:
€: 2,24 / IVA: 2,72

📦 1/12



CORTA PIZZA INOX
ROULETTE À PIZZA INOX
ST.STEEL PIZZA CUTTER
ROTELLA PER PIZZA INOX
CORTA PIZZA INOX

4100 1643:
€: 1,87 / IVA: 2,27

📦 1/12



CORTADOR MASA INOX
ROULETTE COUPE-PÂTES INOX
ST.STEEL PASTA CUTTER
ROTELLA TAGLIAPASTA INOX
CORTA MASSA INOX

4100 1644:
€: 1,49 / IVA: 1,81

📦 1/12



COCINA / CUISINE / KITCHEN / CUCINA / COZINHA

Utensilios / Ustensiles / Kitchen utensils / Utensili / Utensílios

Mod. Gravina



TAPA SALPICADURAS INOX
COUVERCLE ANTI-PROJECTIONS INOX
ST.STEEL SPLATTER SCREEN
CUCINA POT COPERTURA INOX
ANTI-SALPICOS INOX

4100 1646: Ø260mm

€: 4,33 / IVA: 5,24

1/12

4100 1647: Ø280mm

€: 4,55 / IVA: 5,51

1/12



ESPÁTULA SILICONA INOX
SPATULE EN SILICONE AVEC MANCHE INOX
SILICONE SCRAPER WITH ST.STEEL HANDLE
SPATOLA IN SILICONE
ESPÁTULA DE SILICONE INOX

4100 1661:

€: 2,32 / IVA: 2,81

1/12



PINCEL SILICONA M/INOX
PINCEAU À PÂTISSERIE EN SILICONE INOX
ST.STEEL SILICONE PASTRY BRUSH
PENNELLO IN SILICONE
PINCEL DE SILICONE INOX

4100 1662:

€: 2,67 / IVA: 3,24

1/12



Mod. Gravina

RALLADOR 4 CARAS INOX
RÂPE 4 FACES INOX
4 FACES GRATER
GRATTUGIA A 4 LATI INOX
RALADOR 4 CARAS INOX



4100 1670: 170x80x50 mm
€: 2,85 / IVA: 3,45

1/12



4100 1671: 240x100x70 mm
€: 5,33 / IVA: 6,45

1/12

COLADOR MALLA INOX
PASSOIRE INOX
ST.STEEL STRAINER
COLINO A MAGLIA
COADOR DE REDE INOX

4100 1680: Ø70mm

€: 2,37 / IVA: 2,87

1/12

4100 1681: Ø80mm

€: 2,90 / IVA: 3,51

1/12

4100 1682: Ø90mm

€: 3,48 / IVA: 4,22

1/12

4100 1683: Ø100mm

€: 3,68 / IVA: 4,45

1/12

4100 1684: Ø120mm

€: 4,30 / IVA: 5,21

1/12

4100 1685: Ø140mm

€: 5,18 / IVA: 6,27

1/12





Gravina

Mod. Gravina

SACACORCHOS CROMADO
TIRE-BOUCHON CHROMÉ
CORKSCREW CHROMED
VINO APRIBOTTIGLIE BICROMATO
SACA ROLHAS

4100 1672:
€: 6,99 / IVA: 8,46

1/12



SACACORCHOS MULTIUSOS
TIRE-BOUCHON DOUBLE LEVIER
DOUBLE LEVER CORKSCREW
VINO APRIBOTTIGLIE MULTIFUNZIONE
SACA ROLHAS MULTI-FUNÇÕES

4100 1674:
€: 1,69 / IVA: 2,05

1/12



SACACORCHOS
TIRE-BOUCHON
CORKSCREW
VINO APRIBOTTIGLIE
SACA ROLHAS

4100 1673:
€: 3,48 / IVA: 4,22

1/12



SACACORCHOS PROFI
TIRE-BOUCHON DOUBLE LEVIER PROFI
CORKSCREW DOUBLE LEVEL PROFI
VINO APRIBOTTIGLIE PROFI
SACA ROLHAS MULTI-FUNÇÕES PROFI

4100 1675:
€: 2,31 / IVA: 2,80

1/12



COCINA / CUISINE / KITCHEN / CUCINA / COZINHA

Utensilios / Ustensiles / Kitchen utensils / Utensili / Utensílios

Mod. Udai

Colección de utensilios para cocinar fabricados en nylon antiadherente, antirayaduras y resistentes al calor. Presentan un atractivo diseño funcional y práctico en color gris antracita.

Gamme d'ustensiles de cuisine fabriqués en nylon anti-adhésif, anti-rayure et résistantes à la chaleur. Design fonctionnel et pratique, couleur gris anthracite.

A collection of utensils to cook made of non-stick nylon, scratch and heat resistant. An attractive functional design in anthracite grey colour.

Collezione di utensili per la cucina fabbricati in nylon antiaderente, antigraffio e resistenti al calore. Presentano un design accattivante e pratico, di colore grigio antracite.

Coleção de utensilios para cozinhar feitos em nylon antiaderente, anti riscos e resistente ao calor. Design atraente funcional e pratico em cinza antracite.

SOPORTE 5 UTENSILIOS DE COCINA SUPPORT 5 USTENSILES DE CUISINE BRACKET FOR 5 KITCHEN TOOLS SUPPORTO PER 5 UTENSILI DA CUCINA SUPORTE P/ 5 UTENSÍLIOS DE COZINHA



4160 0385:
€: 1,69 / IVA: 2,05

 1/15

Utensilios no incluidos.
Ustensiles non inclus.
Utensils not included.
Utensili non inclusi.
Utensílios não incluídos.



Mod. Udai

CAZO
LOUCHE
LADLE
MESTOLO
CONCHA



4160 0380:
€: 1,09 / IVA: 1,32

📦 1/15

CUCHARÓN
LOUCHE
LADLE
CUCCHIAIO
COLHER GRANDE



4160 0381:
€: 1,09 / IVA: 1,32

📦 1/15

ESPUMADERA
ÉCUMOIRE
SLOTTED SPOON
SCHIUMAROLA
COLHER ESCORREDORA



4160 0382:
€: 1,09 / IVA: 1,32

📦 1/15

RASERA
PALETTE
FISH SLICE
SPATOLA FORATA
ESPÁTULA PERFURADA



4160 0383:
€: 1,09 / IVA: 1,32

📦 1/15

CUCHARA PASTA
CUILLÈRE A PÂTES
PASTA LADLE
SERVISPAGHETTI
PEGADOR P/ MASSA



4160 0384:
€: 1,09 / IVA: 1,32

📦 1/15

COCINA / CUISINE / KITCHEN / CUCINA / COZINHA

Utensilios / Ustensiles / Kitchen utensils / Utensili / Utensílios



Pasapurés fabricado en PP de 22 cm de diámetro, con dos discos intercambiables tamizadores de acero inoxidable para distintos tamaños de rallado. Estructura para tamizar sobre cualquier recipiente.

Presse-purée fabriqué en PP de diamètre 22 cm, avec deux disques interchangeables tamiseurs en inox pour différentes tailles de pressoir. Dispose d'une structure pour tamiser sur tout type de récipient.

Food mill manufactured in PP, 22 cm diameter. It has two interchangeable grating discs made of stainless steel with different grating sizes. It also has a structure to sieve on any container.

Passaverdure fabbricato in PP con diametro di 22 cm, con due dischi intercambiabili in acciaio inossidabile di dimensioni diverse per scegliere la grana di passatura corretta. Dispone di una struttura che ne consente il posizionamento sopra qualsiasi altro recipiente.

Passevite fabricado em PP de diâmetro 22 cm, com dois discos de aço inoxidável intercambiáveis com diferentes tamanhos para ralar. Tem estrutura para passar os alimentos sobre qualquer recipiente.

PASAPURÉS INOX 2 DISCOS
MOULIN À LÉGUMES 2 GRILLES
FOOD MILL 2 DISCS
PASSAVERDURE 2PZI
MOINHO DE LEGUMES 2 GRELHAS

4100 1690: Ø220mm

€: 6,37 / IVA: 7,71

1/12



COCINA / CUISINE / KITCHEN / CUCINA / COZINHA

Utensilios / Ustensiles / Kitchen utensils / Utensili / Utensílios



Jamoneros y soportes de jamón en madera con herrajes de hierro pintado y pintura atóxica antioxidante. Modelo especial giratorio para realizar cortes precisos y profesionales. Cuchillo Jamonero 30 cm especial con protección y guía de corte, que permite cortar lonchas de jamón de manera fácil y segura. Hoja en acero inoxidable con aleación de Molibdeno Vanadio (mayor dureza).

Support à jambon, en bois avec des fixation en fer, peinture non toxique antioxydant. Modèle spécial rotatif permettant d'effectuer des coupes précises et professionnelles. Couteau 30 cm spécial avec protection et guide de coupe permettant de couper des tranches de jambon facilement et en toute sécurité. Lame en acier inoxydable avec alliage molybdène vanadium (meilleure résistance).

Spanish ham stand made of wood with painted iron fittings. Non-poisonous and antioxidant paint. Special rotating model to make professional and accurate cuts. Special 30 cm ham slicing knife with protection and cutting guide that enables a safe and easy way of cutting ham slices. Stainless steel blade with molybdenum and vanadium alloy (greater hardness).

Porta prosciutto in legno con fissaggi in ferro verniciato e vernice antiossidante, non tossica. Modello speciale, rotante, per realizzare tagli precisi e professionali. Coltello da 30cm, con protezione e guida che consente il taglio del prosciutto in maniera facile e sicura. Lama in acciaio inox al Molibdeno Vanadio (maggiore durezza).

Suportes em madeira para Presunto com ferragens de ferro pintado e pintura antioxidante e não-tóxica. Modelo especial rotativo para fazer cortes precisos e profissionais. Faca de presunto 30 cm especial com proteção e guia de corte que permite cortar fatias de presunto com facilidade e segurança. Chapa de aço inoxidável com liga de Molibdênio vanádio (mais dureza)

SOPORTE JAMONERO GÓNDOLA MODELO "RESERVA"
SUPPORT JAMBON MODELE "RESERVA"
SPANISH HAM STAND "RESERVA" MODEL
SUPPORTO PROSCIUTTO MODELLO "RECEBO"
SUPORTE DE PRESUNTO MODELO "RECEBO"



4100 2711:
€: 10,12 / IVA: 12,24



JAMONERO MODELO "RECEBO"
COUTEAU A JAMBON MODELE "RECEBO"
SPANISH HAM STAND "RECEBO MODEL"
PROSCIUTTO MODELLO "RECEBO"
P/ PRESUNTO MODELO "RECEBO"



4100 2712:
€: 148,82 / IVA: 180,08



COCINA / CUISINE / KITCHEN / CUCINA / COZINHA

Utensilios / Ustensiles / Kitchen utensils / Utensili / Utensílios

SOPORTE JAMONERO TUBO METAL
SUPPORT JAMBON TUBE MÉTAL
SPANISH HAM STAND METAL TUBE
SUPPORTO PROSCIUTTO, TUBO METALLICO
SUPORTE PARA PRESUNTO, TUBO METAL



4100 2715:
€: 21,46 / IVA: 25,97

1

SOPORTE JAMONERO CON HUSILLO
SUPPORT JAMBON AVEC BROCHE
SPANISH HAM STAND WITH SPINDLE
SUPPORTO PROSCIUTTO CON MANDRINO
SUPORTE PARA PRESUNTO, COM FUSO



4100 2716:
€: 36,45 / IVA: 44,10

1

**CUCHILLO JAMONERO C/PROTECCIÓN
COUPEAU A JAMBON AVEC PROTECTION
HAM SLICING KNIFE W/COVER
COLELLO PROSCIUTTO CON PROTEZIONE
FACA DE PRESUNTO C/ PROTEÇÃO**



4100 2735: 300mm
€: 20,93 / IVA: 25,33

📦 1

**GUANTE ANTICORTE ACERO INOX CARNICERO
GANTS ACIER INOX BOUCHER
BUTCHER STAINLESS STEEL GLOVES
GUANTO ACCIAIO INOX MACELLAIO
LUVAS DE AÇO INOX DE CARNICEIRO**

Guantes especiales anticorte fabricados en acero inoxidable especial para carniceros y manipuladores de elementos cortantes. Modelo ambidiestro profesional, fabricados en malla metálica de "Acero Inox".

Gants spéciaux anti coupure fabriqués en acier inoxydable spécial pour Bouchers et personnes en contact d'éléments coupants. Modèle ambidextre professionnel, fabriqués en maille métallique en "Acier Inox".

Special cut-resistant gloves made of stainless steel. Appropriate for butchers and also for handling sharp elements. Professional ambidextrous model with a stainless steel metal mesh.

Guanti speciali antitaglio fabbricati in acciaio speciale inox, per macellai e manipolatori di elementi da tagliare. Modello professionale, ambidestro. Fabbricato in maglia metallica in "Acciaio Inox".

Luvas especiais anti corte, feitas de aço inoxidável especial para talhos e manipuladores de elementos de corte. Modelo profissional ambidestro, fabricado em malha de metal "Aço Inoxidável".



4100 2730M: T: M
€: 79,50 / IVA: 96,20
📦 1

4100 2730XL: T: XL
€: 79,50 / IVA: 96,20
📦 1

4100 2730L: T: L
€: 79,50 / IVA: 96,20
📦 1

COCINA / CUISINE / KITCHEN / CUCINA / COZINHA

Utensilios / Ustensiles / Kitchen utensils / Utensili / Utensílios

TIJERAS DE COCINA PROFESIONAL CISEAUX DE CUISINE PROFESSIONNEL PROFESSIONAL KITCHEN SCISSORS FORBICE PROFESSIONALE DA CUCINA TESOURAS DE COZINHA PROFISSIONAL

Tijeras de Cocina Profesional en acero Inoxidable de modelo clásico, aptas para el corte de todo tipo de alimentos, con filo especial que evita el resbalamiento de los alimentos al ser cortados.

Ciseaux de cuisine professionnels en acier inoxydable, modèle classique, conçus pour couper tout type d'aliments, avec bord spécial qui évite le glissement des aliments à couper.

Professional stainless steel kitchen scissors. A classic model suitable for cutting all kind of food thanks to its special blade avoiding food slips when cutting foodstuffs.

Forbici professionali da cucina in acciaio inox. Modello classico, adatte per il taglio di tutti i tipi di alimenti con bordo speciale che impedisce lo scivolamento del cibo da tagliare.

Tesouras de cozinha Professional de aço inoxidável, de modelo clássico, adequadas para o corte de todos os tipos de alimentos, com uma aresta especial que evita o deslizamento da comida a ser cortada.



4100 2721: 185mm

€: 6,22 / IVA: 7,53



1

4100 2722: 200mm

€: 8,25 / IVA: 9,99



1

CHAIRA DE AFILAR M. MADERA
FUSIL A AIGUISER M BOIS
SHARPENING STEEL, WOODEN HANDLE
AFFILATORE M LEGNO
AFIADOR DE FACAS M MADEIRA

Chaira metálica de afilar redonda con corte semifino y mango de madera de alta resistencia y durabilidad.

Fusil métallique à aiguiser rond avec coupe mi-fine et manche en bois très résistant, longue durée de vie.

Round metal sharpening steel, semi-thin cut and a wooden handle of high resistance and durability.

Acciaino metallico con taglio semifine e manico in legno ad alta resistenza e durata.

Afiador de metal redondo com corte semi fino e cabo de madeira de alta resistência e durabilidade.



4100 2525BL: 200mm

€: 8,28 / IVA: 10,02



AFILADOR "MOD. SANSÓN" PROFESIONAL
AIGUISEUR "MOD.SANSON" PROFESSIONNEL
PROFESSIONAL KNIFE SHARPENER "SANSON MODEL"
AFFILATORE "MOD.SANSON" PROFESSIONALE
AFIADOR "MOD.SANSON" PROFISSIONAL

Afilador "SANSÓN" con cuerpo de aluminio indicado para todo tipo de cuchillos, herramientas de corte, tijeras, hachas, cizallas, etc.

Aiguiser SANSON "avec corps en aluminium, idéal pour aiguiser tout type de couteaux, outils de coupe, ciseaux, haches, cisailles, etc..

Knife sharpener "SANSON" with an aluminium body suitable for all kinds of knives, cutting tools, scissors, axes, hedge shears, etc.

Acciaino "SANSON" con corpo in alluminio, indicato per tutti i tipi di coltelli, strumenti da taglio, forbici, asce, cesoie, ecc.

Afiador "SANSON" com corpo de aluminio adecuado para todos o tipo de facas, ferramentas de corte, tesouras, machado, cisalhas, etc.



4100 2599:

€: 27,36 / IVA: 33,11



COCINA / CUISINE / KITCHEN / CUCINA / COZINHA

Cubertería y cuchillería / Couverts et Coutellerie / Cutlery / Posateria e Coltelleria / Talheres e Cutelaria



Mod. Ginger

Tacoma (Portacuchillos) de Poli-Fibra en color negro. Para guardar todos tus cuchillos y utensilios de cocina. Mantiene cuchillos guardados con los filos protegidos. Se adapta a cualquier tamaño. Cuchillos Cocinero Modelo "Cider" inoxidable con mangos inyectados de Polipropileno texturizado, para usos continuados en condiciones parecidas a los ambientes profesionales.

Tacoma (Support couteaux) en polyfibre de couleur noire. Pour tous les couteaux et ustensiles de cuisine. Permet de ranger les couteaux avec les bords protégés, il s'adapte à toutes les tailles. Couteaux de Cuisinier Modèle Cider" inoxydables avec manches en Polypropylène brossé pour utilisations quotidiennes en conditions identiques aux environnements professionnels."

Black Tacoma (Knife holder) made from polyfibre. Designed to keep blades of all knives protected as well as other kitchen utensils. It fits any size. Stainless steel chef's knives, "Cider" model, with injection molded PP handles suitable for a daily use under similar conditions to professional environments.

Portacoltelli in polifibra di colore nero. Per riporre tutti i tipi di coltelli e utensili da cucina. Conserva le lame dei coltelli adattandosi a qualsiasi dimensione. Coltelli da cucina Modello "Cider" inox con manici in Polipropilene testurizzato, per utilizzi continuativi in ambienti professionali.

Suporte (Porta facas) de Poly-fibra na cor preta. Para guardar todas as suas facas e utensilios cozinha. Mantém as facas guardadas com as lâminas protegidas, adapta-se a qualquer tamanho. Facas Cozinheiro Modelo "Cider" inoxidável com cabos injetados com polipropileno texturizado, para usos frequentes em condições parecidas aos ambientes profissionais.



**TACOMA ESPECIAL POLIFIBRA
TACOMA SPÉCIAL POLYFIBRE
SPECIAL BLACK POLYFIBRE TACOMA
PORTACOLTELLI SPECIALE IN POLIFIBRA
SUPORTE PARA FACAS ESPECIAL POLIFIBRA**

4100 2499:

€: 31,35 / IVA: 37,94

 1



Mod. Ginger



PUNTILLA COCINERO
COUPEAU CUISINE
CHEF'S KNIFE
COLTELLO A PUNTA CUCINA
FACA PONTIAGUDA COZINHEIRO

4100 2482: 150mm
€: 4,90 / IVA: 5,93



CUCHILLO COCINERO
COUPEAU CUISINE
CHEF'S KNIFE
COLTELLO CUCINA
FACA DE COZINHEIRO

4100 2483: 200mm
€: 7,65 / IVA: 9,26



CUCHILLO COCINERO
COUPEAU CUISINE
CHEF'S KNIFE
COLTELLO CUCINA
FACA DE COZINHEIRO

4100 2484: 230mm
€: 9,65 / IVA: 11,68



JAMONERO COCINERO
COUPEAU JAMBON
HAM SLICING KNIFE
COLTELLO PROSCIUTTO
FACA DE PRESUNTO

4100 2485: 260mm
€: 11,15 / IVA: 13,50



PANERO COCINERO
COUPEAU A PAIN
BLACK BREAD KNIFE
COLTELLO PANE
FACA DE PÃO

4100 2486: 210mm
€: 10,50 / IVA: 12,71



Mod. Ginger

Cuchillos de Recolección con punta redondeada, punta curva redonda y modelo pico pato, ideales para recolección y manipulación de frutas y hortalizas.

Couteaux de récolte avec pointe arrondie, pointe courbée ronde et bout bec de canard, idéals pour récolte et manipulation de fruits et de légumes.

Harvest knives with round point, curved point and curved edge suitable for harvesting and handling fruits and vegetables.

Coltelli da raccolta a punta rotonda, curva e ricurva. Ideali per la raccolta e la manipolazione di frutta e ortaggi.

Facas de colheita com ponta arredondada, ponta curva redonda e modelo pico pato, ideais para a colheita e manuseio de frutas e legumes.



Ginger

Mod. Ginger



CUCHILLO RECOLECCIÓN PUNTA REDONDA
 COUTEAU RECOLE POINTE RONDE
 HARVEST KNIFE WITH ROUND POINT
 COLELLO DA RACCOLA A PUNTA TONDA
 FACA DE PODAR PONTA REDONDA

4100 2181: 45mm
 Pack 12 uds - €: 14,00 / IVA: 16,95



CUCHILLO RECOLECCIÓN PICO PATO
 COUTEAU RECOLE BEC PEROQUET
 HARVEST KNIFE CURVED EDGE
 COLELLO DA RACCOLA CON LAMA RICURVA
 FACA DE TORNEAR BICO DE PATO

4100 2182: 45mm
 Pack 12 uds - €: 14,83 / IVA: 17,95



PUNTILLAS RECOLECCIÓN CURVA REDONDA
 COUTEAU RECOLE POINTE COURBEE
 HARVEST KNIFE WITH CURVED POINT
 COLELLO DA RACCOLA A PUNTA CURCA
 FACA DE DESCASCAR PONTA CURVA

4100 2183: 60mm
 Pack 12 uds - €: 14,83 / IVA: 17,95

COCINA / CUISINE / KITCHEN / CUCINA / COZINHA

Cubertería y cuchillería / Couverts et Coutellerie / Cutlery / Posateria e Coltelleria / Talheres e Cutelaria

Mod. Ginger

Cuchillos Serie Modelo "Ginger" inoxidable con mangos inyectados de PP, funcionales y adecuados para usos en condiciones de seguridad e higiene.

Couteaux série modèle Ginger " inoxydable avec des manches en PP, fonctionnels et appropriés pour utilisations demandant sécurité et hygiène."

Stainless steel knives "Ginger" model with injection molded PP handles. Functional knives suitable for using in safety and hygienic conditions.

Serie di coltelli, modello "Ginger" inox con manici in Polipropilene, funzionali e adatti per utilizzi in condizioni di sicurezza e igiene.

Facas série modelo "Ginger" inoxidável com cabos injetados de PP, funcionais e adequados para uso em condições de saúde e segurança.



**CUCHILLO MONDADOR
COUPEAU EPLUCHEUR
PARING KNIFE
SPELUCCHINO
DESCASCADOR**

4100 2471: 70mm
Pack 12 uds
€: 15,95 / IVA: 19,30

**CUCHILLO COCINA
COUPEAU CUISINE
KITCHEN KNIFE
COLELLO CUCINA
FACA DE COZINHA**

4100 2474: 105mm
Pack 12 uds
€: 17,05 / IVA: 20,64

**CUCHILLO COCINA MICRODENTADO
COUPEAU CUISINE MICRO
MICRO KITCHEN KNIFE
COLELLO DA CUCINA MICRO
FACA DE COZINHA MICRO**

4100 2475: 105mm
Pack 12 uds
€: 17,05 / IVA: 20,64



EXPOSITOR 36 PUNTILLAS AMOLADAS
PRESENTOIR 36 COUTEAUX LAMES LISSES 36
D,STAND SHARP EDGE KNIVES
ESPOSITORE 36 COLELLI A PUNTA AFFILTATA
EXPOSITOR PARA 36 FACAS DE PONTA AGUÇADA

4100 2472: 90mm
€: 69,25 / IVA: 83,80



PUNTILLA COCINA
COUPEAU DE CUISINE
PARING KNIFE
COLELLO A PUNTA DA CUCINA
FACA PONTIAGUDA COZINHA

● 4100 2472N: 90mm Pack 12 uds €: 20,22 / IVA: 24,47
● 4100 2472R: 90mm Pack 12 uds €: 20,22 / IVA: 24,47
● 4100 2472V: 90mm Pack 12 uds €: 20,22 / IVA: 24,47



EXPOSITOR 36 PUNTILLAS PERLADAS
PRESENTOIR 36 COUTEAUX LAMES DENTEES
36 D,STAND ROUNDED EDGE KNIVES
ESPOSITORE 36 COLELLI A PUNTA TONDA
EXPOSITOR PARA 36 FACAS DE PONTA REDONDA

4100 2473: 105mm
€: 82,77 / IVA: 100,15



PUNTILLA PERLADA PROFI
COUPEAU LAME DENTEE PROFI
ROUNDED EDGE KNIFE PROFI
COLELLO A PUNTA TONDA PROFESS.
FACA PONTA REDONDA PROFI

● 4100 2473N: 105mm Pack 12 uds €: 27,59 / IVA: 33,39
● 4100 2473R: 105mm Pack 12 uds €: 27,59 / IVA: 33,39
● 4100 2473V: 105mm Pack 12 uds €: 27,59 / IVA: 33,39



COCINA / CUISINE / KITCHEN / CUCINA / COZINHA

Cubertería y cuchillería / Couverts et Coutellerie / Cutlery / Posateria e Coltelleria / Talheres e Cutelaria



Saffron

Mod. Saffron

Cuchillos Serie Modelo "Saffron" inoxidables con diseño clásico profesional y mango especial POM. Cuchillos enterizos ensamblados con 3 remaches.

Couteaux Série modèle Saffron" inoxydables avec conception classique professionnelle et manche spécial POM. Couteaux de chasse assemblés avec 3 rivets".

Stainless steel knives "Saffron" model with a professional classic desing and a special POM handle. Full tang knives assembled with 3 rivets.

Serie di coltelli, modello "Saffron" inox con design classico, professionale e manico speciale in POM. Coltelli interamente assemblati con 3 rivettini.

Facas série modelo "Saffron" inoxidável com design clássico profissional e cabo especial POM. Facas integralmente montadas com 3 rebites.



**CUCHILLO MONDADOR
COUPEAU EPLUCHEUR
PARING KNIFE
SPELUCCHINO
DESCASCADOR**

4100 2510BL: 110mm
€: 6,78 / IVA: 8,21

1



Mod. Saffron



CUCHILLO VERDURAS
COUPEAU LEGUMES
VEGETABLE KNIFE
COLELLO VERDURE
FACA DE LEGUMES

CUCHILLO COCINERO
COUPEAU CUISINIER
CHEF'S KNIFE
COLELLO CUCINA
FACA DE COZINHEIRO

CUCHILLO PANERO
COUPEAU A PAIN
BREAD KNIFE
COLELLO PANE
FACA DE PÃO

CUCHILLO JAMONERO
COUPEAU JAMBON
HAM SLICING KNIFE
COLELLO PROSCIUTTO
FACA DE PRESUNTO

CUCHILLO SANTOKU
COUPEAU SANTOKU
SANTOKU KNIFE
COLELLO SANTOKU
FACA SANTOKU

MACHETA COCINERO
MACHETTE DE CUISINIER
MACHETE KNIFE
MANNAIA DA CUCINA
CUTELO DE COZINHEIRO

4100 2512BL: 150mm
€: 10,35 / IVA: 12,53

4100 2514BL: 200mm
€: 12,68 / IVA: 15,35

4100 2517BL: 200mm
€: 11,22 / IVA: 13,58

4100 2518BL: 240mm
€: 14,40 / IVA: 17,43

4100 2519BL: 175mm
€: 16,20 / IVA: 19,61

4100 2520BL: 200mm
€: 24,06 / IVA: 29,12

📦 1

📦 1

📦 1

📦 1

📦 1

📦 1

COCINA / CUISINE / KITCHEN / CUCINA / COZINHA

Cubertería y cuchillería / Couverts et Coutellerie / Cutlery / Posateria e Coltelleria / Talheres e Cutelaria



Cider

Mod. Cider



Cuchillos Serie Modelo "Cider" inoxidable con mangos clásicos de polipropileno, funcionales y adecuados para usos en condiciones de seguridad e higiene.

Couteaux série modèle Cider " inoxydable avec manche classique en polypropylène, fonctionnels et appropriés pour des utilisations demandant sécurité et hygiène".

Stainless steel knives "Cider" model with classic handles made from polypropylene, functional and suitable for using in safety and hygienic conditions.

Serie di coltelli, modello "Cider", inox con manici classici in polipropilene. Funzionali e adatti per utilizzi in condizioni di sicurezza e igiene.

Facas série modelo "Cider" inoxidável com pegas clássicas de polipropileno, funcionais e adequadas para usos em segurança e higiene.



EXPOSITOR 36 PUNTILLAS COCINA
PRESENTOIR 36 LAMES CUISINE
36 EXPOSITOR PUNTILLA COCINA
ESPOSITORE 36 COLELLI DA CUCINA
EXPOSITOR P/ 36 FACAS DE COZINHA

4100 2231: 90mm
€: 104,70 / IVA: 126,70



PUNTILLA COCINA
COUPEAU DE CUISINE
PARING KNIFE
COLELLO A PUNTA DA CUCINA
FACA PONTIAGUDA COZINHA

● **4100 2231N: 90mm**
Pack 12 uds - **€: 38,32 / IVA: 46,37**

● **4100 2231R: 90mm**
Pack 12 uds - **€: 38,32 / IVA: 46,37**

● **4100 2231V: 90mm**
Pack 12 uds - **€: 38,32 / IVA: 46,37**



COCINA / CUISINE / KITCHEN / CUCINA / COZINHA

Cubertería y cuchillería / Couverts et Coutellerie / Cutlery / Posateria e Coltelleria / Talheres e Cutelaria

Mod. Cider



CUCHILLO MONDADOR
COUTEAU EPLUCHEUR
PARING KNIFE
SPELUCCHINO
DESCASCADOR

4100 2232: 90 mm
Pack 12 uds - €: 29,12 / IVA: 35,24

4100 2232BL: 90 mm
€: 2,94 / IVA: 3,56



CUCHILLO COCINA
COUTEAU CUISINE
KITCHEN KNIFE
COLELLO DA CUCINA
FACA DE COZINHA

4100 2233: 100mm
Pack 12 uds - €: 31,32 / IVA: 37,90

4100 2233BL: 100mm
€: 3,11 / IVA: 3,77



CUCHILLO COCINA MICRODENTADO
COUTEAU CUISINE MICRO
MICRO KITCHEN KNIFE
COLELLO CUCINA MICRO
FACA DE COZINHA MICRO

4100 2234: 100mm
Pack 12 uds - €: 32,98 / IVA: 39,91

4100 2234BL: 100mm
€: 3,26 / IVA: 3,95



CUCHILLO COCINA
COUTEAU CUISINE
KITCHEN KNIFE
COLELLO DA CUCINA
FACA DE COZINHA

4100 2235: 130mm
Pack 12 uds - €: 33,80 / IVA: 40,90

4100 2235BL: 130mm
€: 3,31 / IVA: 4,01



Mod. Cider



CUCHILLO COCINA MICRODENTADO
COUPEAU CUISINE MICRO
MICRO KITCHEN KNIFE
COLELLO CUCINA MICRO
FACA DE COZINHA MICRO

4100 2236: 130mm
Pack 12 uds - €: 36,25 / IVA: 43,86

4100 2236BL: 130mm
€: 3,53 / IVA: 4,28
1



CUCHILLO JAMONERO
COUPEAU JAMBON
HAM SLICING KNIFE
COLELLO DA PROSCIUTTO
FACA DE PRESUNTO

4100 2239BL: 240mm
€: 6,05 / IVA: 7,33
1



HACHUELA COCINA
HACHOIRS CUISINE
CLEAVER
MANNAIA DA CUCINA
CUTELO COZINHA

4100 2240BL: 160mm
€: 11,98 / IVA: 14,50
1

COCINA / CUISINE / KITCHEN / CUCINA / COZINHA

Cubertería y cuchillería / Couverts et Coutellerie / Cutlery / Posateria e Coltelleria / Talheres e Cutelaria

Mod. Garlic



CUCHILLO COCINA
COUTEAU CUISINE
KITCHEN KNIFE
COLELLO CUCINA
FACA DE COZINHA

4100 2196BL: 150mm
€: 4,70 / IVA: 5,69



CUCHILLO JAMONERO
COUTEAU JAMBON
HAM SLICING KNIFE
COLELLO PROSCIUTTO
FACA DE PRESUNTO

4100 2199BL: 240mm
€: 6,05 / IVA: 7,33



CUCHILLO MONDADOR
COUTEAU EPLUCHEUR
PARING KNIFE
SPELUCCHINO
DESCASCADOR

4100 2191: 90mm
Pack 12 uds - €: 29,12 / IVA: 35,24

4100 2191BL: 90mm
€: 2,92 / IVA: 3,54
 1



Cuchillos Serie Modelo "Garlic" inoxidable con clásico mango en madera de Kotibe.

Couteaux série modèle "Garlic" inoxydables avec manche classique en bois de Kotibe.

Stainless steel knives "Garlic" model with classic handle made of Kotibe wood.

Serie di coltelli, modello "Garlic", inox con manico classico in legno di Kotibe.

Facas Série Modelo "Garlic" inoxidável com cabo clássico em madeira de Kotibe.



Mod. Garlic

CUCHILLO VERDURAS
COUPEAU LEGUMES
VEGETABLE KNIFE
COLELLO PER VERDURE
FACA P/ LEGUMES

4100 2192: 100mm
Pack 12 uds
€: 31,30 / IVA: 37,89

4100 2192BL: 100mm
€: 3,12 / IVA: 3,78
📦 1



CUCHILLO VERDURAS MICRODENTADO
COUPEAU LEGUMES MICRODÉNTÉ
MICRO VEGETABLE MICRO-SERRATED
COLELLO PER VERDURE MICRODENTATO
FACA P/ LEGUMES MICRO DENTADO

4100 2193: 100mm
Pack 12 uds
€: 32,98 / IVA: 39,91

4100 2193BL: 100mm
€: 3,23 / IVA: 3,91
📦 1



CUCHILLO COCINA
COUPEAU DE CUISINE
KITCHEN KNIFE
COLELLO CUCINA
FACA DE COZINHA

4100 2194: 130mm
Pack 12 uds
€: 33,80 / IVA: 40,90

4100 2194BL: 130mm
€: 3,31 / IVA: 4,01
📦 1



CUCHILLO COCINA MICRODENTADO
COUPEAU DE CUISINE MICRODÉNTÉ
KITCHEN KNIFE MICRO-SERRATED
COLELLO CUCINA MICRO MICRODENTATO
FACA DE COZINHA MICRO DENTADO

4100 2195: 130mm
Pack 12 uds
€: 36,26 / IVA: 43,87

4100 2195BL: 130mm
€: 3,52 / IVA: 4,26
📦 1



COCINA / CUISINE / KITCHEN / CUCINA / COZINHA

Cubertería y cuchillería / Couverts et Coutellerie / Cutlery / Posateria e Coltelleria / Talheres e Cutelaria



Mod. Spice

Cubiertos en formato "Chuletero" disponibles en tenedores, cucharas y cuchillos de carne, con mangos de plástico en sensación madera.

Couverts en format 'chuleteros' disponibles en fourchettes, cuillères et couteaux à viande, avec manche en plastique sensation bois.

Steak cutlery. Forks, spoons and knives to cut meat with plastic handles simulating wood.

Posate da carne: forchette, cucchiari e coltelli con manici in plastica, stile legno.

Talheres próprios para carne, disponíveis em garfo, colher e facas para carne, com cabos em plástico imitando madeira.



Mod. Spice

CUCHILLO CHULETERO SENSACIÓN MADERA
COUTEAUX A VIANDE SENSATION BOIS
SIMULATING WOOD CHOP KNIFE
COLELLI DA BISTECCA STILE LEGNO
FACA CHURRASCO IMITANDO MADEIRA

4100 2651BL: 110mm
Pack 6 uds - €: 12,50 / IVA: 15,12

TENEDOR CHULETERO SENSACIÓN MADERA
FOURCHETTES SENSATION BOIS
SIMULATING WOOD CHOP FORK
FORCHETTE DA BISTECCA STILE LEGNO
GARFO CHURRASCO IMITANDO MADEIRA

4100 2652BL: 90mm
Pack 6 uds - €: 13,70 / IVA: 16,58

CUCHARA CHULETERO SENSACIÓN MADERA
CUILLERES SENSATION BOIS
SIMULATING WOOD CHOP SPOON
CUCCHIAI DA BISTECCA STILE LEGNO
COLHER CHURRASCO IMITANDO MADEIRA

4100 2653BL: 90mm
Pack 6 uds - €: 13,70 / IVA: 16,58



COCINA / CUISINE / KITCHEN / CUCINA / COZINHA

Cubertería y cuchillería / Couverts et Coutellerie / Cutlery / Posateria e Coltelleria / Talheres e Cutelaria



Basil

Mod. Basil

Cubiertos en formato "Chuleteros" disponibles en tenedor, cuchara y cuchillos de carne, con mangos en madera prensada.

Couverts en format 'chuleteros' disponibles en fourchettes, cuillères et couteaux à viande, avec manche en bois pressé.

Steak cutlery: Forks, spoons, and knives to cut meat with handles made of pressed wood.

Posate da carne: forchette, cucchiari e coltelli con manici in legno pressato.

Talheres próprios para carne, disponíveis em garfo, colher e facas para carne, com cabos em madeira prensada.



**CUCHILLO CHULETERO MADERA
COUTEAUX A VIANDE BOIS
CHOP KNIFE WOOD
COLELLI DA BISTECCA LEGNO
FACA CHURRASCO MADEIDA**

4100 2656BL: 110mm
Pack 6 uds - €: 15,26 / IVA: 18,47

**TENEDOR CHULETERO MADERA
FOURCHETTES BOIS
CHOP FORK WOOD
FORCHETTE DA BISTECCA LEGNO
GARFO CHURRASCO MADEIDA**

4100 2657BL: 90mm
Pack 6 uds - €: 16,87 / IVA: 20,42

**CUCHARA CHULETERO MADERA
CUILLERES BOIS
CHOP SPOON WOOD
CUCCHIAI DA BISTECCA LEGNO
COLHER CHURRASCO MADEIDA**

4100 2658BL: 90mm
Pack 6 uds - €: 16,87 / IVA: 20,42

COCINA / CUISINE / KITCHEN / CUCINA / COZINHA

Cubertería y cuchillería / Couverts et Coutellerie / Cutlery / Posateria e Coltelleria / Talheres e Cutelaria



Siena

Mod. Siena

Cubiertos en Acero Inox 18-C modelo Siena.
Modelos en cuchillos de mesa, cucharas de
mesa, tenedores de mesa y cucharillas de café.

Couverts en Acier Inox 18-C modèle Sienne.
Modèles en couteaux de table, cuillères de
table, fourchettes de table et petites cuillères
à café.

18-C stainless steel cutlery, Siena model.
Knives, spoons, forks and teaspoons.

Posate da tavola in Acciaio Inox 18-C, Modello
Siena. Cucchiari, coltelli, forchette e cucchiaini
da caffè.

Talheres em aço Inox 18-C modelo siena.
Modelos em facas de mesa, colheres de mesa,
garfos de mesa e colheres de café.



**CUCHARA SIENA INOX
CUILLERES INOX
ST.STEEL TABLE SPOON
CUCCHIAI INOX
COLHER DE MESA INOX**

4100 2901
Pack 6 uds - €: 11,67 / IVA: 14,12

**CUCHILLO SIENA INOX
COUTEAU INOX
ST.STEEL TABLE KNIFE
COLTELLO INOX
FACA DE MESA INOX**

4100 2921
Pack 6 uds - €: 18,90 / IVA: 22,87

**TENEDOR SIENA INOX
FOURCHETTES INOX
ST.STEEL TABLE FORK
FORCHETTE INOX
GARFO DE MESA INOX**

4100 2911
Pack 6 uds - €: 11,67 / IVA: 14,12

**CUCHARILLA SIENA INOX
CUILLERES À CAFÉ INOX
ST.STEEL COFFEE SPOON
CUILLERES À CAFÉ INOX
COLHER CAFÉ INOX**

4100 2905
Pack 6 uds - €: 8,92 / IVA: 10,80

COCINA / CUISINE / KITCHEN / CUCINA / COZINHA

Cubertería y cuchillería / Couverts et Coutellerie / Cutlery / Posateria e Coltelleria / Talheres e Cutelaria



Mod. Talento

Cubiertos Cofan Home para la línea de mesa, fabricados en acero inoxidable de primera calidad. Con espesores adecuados que les confieren la robustez y la elegancia adecuada.

Couverts de table Cofan Home, fabriqués en acier inoxydable de première qualité. Conçus avec une épaisseur appropriée qui leur permet d'associer robustesse et élégance.

Cutlery Cofan Home manufactured in top-quality stainless steel with suitable thicknesses which confer the proper elegance and sturdiness to these utensils.

Posate Cofan Home della linea per la tavola, fabbricate in acciaio inox di prima qualità. Con spessori adeguati che n conferiscono robustezza ed eleganza.

Talheres Cofan Home para mesa, fabricados em aço inoxidável de primeira qualidade. Com espessuras adequadas que lhes dão robustez e elegância adequada.



Mod. Talento



CUCHILLO MESA TALENTO INOX
COUTEAU INOX
ST.STEEL TABLE KNIFE
COLTELLO INOX
FACA DE MESA INOX

4100 2951
Pack 2 uds - €: 2,73 / IVA: 3,31

TENEDOR MESA TALENTO INOX
FOURCHETTE INOX
ST.STEEL TABLE FORK
FORCHETTE INOX
GARFO DE MESA INOX

4100 2952
Pack 3 uds - €: 1,96 / IVA: 2,38

CUCHARA MESA TALENTO INOX
CUILLERES INOX
ST.STEEL TABLE SPOON
CUCCHIAI INOX
COLHER DE MESA INOX

4100 2953
Pack 3 uds - €: 1,96 / IVA: 2,38

CUCHILLO DE CARNE TALENTO INOX
COUTEAU À STEAK INOX
ST. STEEL STEAK KNIFE
COLTELLO INOX
FACA DE CHURRASCO INOX

4100 2954
Pack 2 uds - €: 3,05 / IVA: 3,70

CUCHARA DE POSTRE TALENTO
CUILLERES À THÉ
TEA SPOON
CUCCHIAI
COLHER DE CHÁ

4100 2955
Pack 6 uds - €: 2,32 / IVA: 2,80

CUCHARA DE CAFÉ TALENTO
CUILLERES À CAFÉ
COFFEE SPOON
CUCCHIAI DI CAFFÈ
COLHER DE CAFÉ

4100 2956
Pack 6 uds - €: 2,13 / IVA: 2,58

COCINA / CUISINE / KITCHEN / CUCINA / COZINHA

Cristalería y Vajilla / Verrerie et vaisselles / Glassware and crockery / Cristalleria e stoviglie / Vidros e louças



Mod. Malberk

Copas y vasos Cofan Home para agua, cerveza, vino, licores, postres y especiales para combinados. Fabricados con materias primas de primera calidad. Reconocidos por la resistencia a los choques térmicos y fabricados para el hogar y la hostelería más exigente, mediante los mejores estándares de durabilidad.

Verres et coupes COFAN Home pour l'eau, la bière, le vin, les liqueurs, desserts et verrines. Fabriqués avec des matières premières de première qualité reconnues pour leur résistance aux chocs thermiques et fabriqués pour la maison et les besoins les plus exigeants de l'hôtellerie, répondant aux meilleurs standards de durabilité.

Goblets and glasses Cofan Home for water, beer, wine, liquors and desserts. Made of top-quality raw materials recognised by their resistance to the thermal shock and made for the most demanding homes and hotel industry thanks to the best standards of durability.

Calici e bicchieri Cofan Home per acqua, birra, vino, liquori, dolci. Realizzati con materiali di alta qualità riconosciuti per la loro resistenza agli shock termici e prodotti specificamente per la casa e le imprese ricettive più esigenti. Il tutto grazie ai migliori standard di durata.

Taças e copos Cofan Home para a água, cerveja, vinho, licores, sobremesas e para combinações especiais. Fabricados com matérias primas de primeira qualidade, reconhecidos pela resistência aos choques térmicos e fabricados para a casa e hotelaria mais exigentes, utilizando os melhores níveis de durabilidade.

Mod. Malberk

VASO WHISKY REFOR
VERRE A WHISKY
WHISKY GLASS
BICCHIERE WHISKY
COPO DE WHISKY



4001 1010: 300 cc
Pack 6 uds
€: 6,20 / IVA: 7,50



VASO TUBO REFOR
VERRE TUBE
TUBE GLASS
BICCHIERE LUNGO
COPO EM TUBO



4001 1011: 300 cc
Pack 6 uds
€: 5,48 / IVA: 6,64



VASO CERVEZA REFOR
VERRE A BIÈRE
BEER GLASS
BICCHIERE PER BIRRA
COPO DE CERVEJA



4001 1012: 380 cc
Pack 6 uds
€: 7,50 / IVA: 9,08



VASO CHUPITO REFOR
VERRE A LIQUEUR
LIQUOR GLASS
BICCHIERINO DA LIQUORE
COPO DE LICOR



4001 1013: 95 cc
Pack 6 uds
€: 3,50 / IVA: 4,24



VASO COMBINADO REFOR
VERRE A EAU
HIGHBALL GLASS
BICCHIERE COKTAIL
COPO COMBINADO



4001 1014: 500 cc
Pack 6 uds
€: 7,35 / IVA: 8,90



COCINA / CUISINE / KITCHEN / CUCINA / COZINHA

Cristalería y Vajilla / Verrerie et vaisselles / Glassware and crockery / Cristalleria e stoviglie / Vidros e louças

Mod. Sarbia

COPA COGNAC
VERRE A COGNAC
COGNAC GLASS
CALICE DA COGNAC
COPO DE CONHAQUE



4001 1120: 390 cc
Pack 6 uds
€: 6,35 / IVA: 7,69



1

COPA DE CERVEZA
VERRE A BIÈRE
TULIP BEER GLASS
CALICE DA BIRRA
TAÇA DE CERVEJA



4001 1121: 400 cc
Pack 6 uds
€: 7,56 / IVA: 9,15



1

COPA GRAN VINO
VERRE A VIN GRAND FORMAT
WINE GLASS
CALICE VINO
TAÇA DE VINHO



4001 1122: 360 cc
Pack 6 uds
€: 7,50 / IVA: 9,08



1

COPA VINO TINTO
VERRE A VIN
RED WINE GLASS
CALICE VINO ROSSO
TAÇA DE VINHO TINTO



4001 1123: 210 cc
Pack 6 uds
€: 5,76 / IVA: 6,97



1

Mod. Sarbia

COPA CHAMPAGNE
FLUTE A CHAMPAGNE
CHAMPAGNE GLASS
CALICE PER CHAMPAGNE
TAÇA DE CHAMPANHE



4001 1124: 190 cc
Pack 6 uds
€: 5,76 / IVA: 6,97



COPA COMBINADOS
VERRE A PIED BALLON
COCKTAIL BALOON GLASS
COPPA COKTAIL
TAÇA COMBINADOS



4001 1125: 645 cc
Pack 6 uds
€: 8,92 / IVA: 10,80



COPA DE CERVEZA
VERRE A BIÈRE
TULIP BEER GLASS
CALICE DA BIRRA
TAÇA DE CERVEJA



4001 1126: 375 cc
Pack 6 uds
€: 8,50 / IVA: 10,29



COPA COCKTAIL
VERRE A COCKTAIL
COCKTAIL GLASS
CALICE PER COCKTAIL
TAÇA DE COCKTAIL



4001 1127: 460 cc
Pack 6 uds
€: 8,60 / IVA: 10,40



COCINA / CUISINE / KITCHEN / CUCINA / COZINHA

Cristalería y Vajilla / Verrerie et vaisselles / Glassware and crockery / Cristalleria e stoviglie / Vidros e louças



Mod. Hampton

VASO CHIQUITO
VERRE A DIGESTIF
ROCKS GLASS
TUMBLER BASSO
COPO PEQUENO



4001 1015: 240 cc
Pack 6 uds
€: 3,46 / IVA: 4,19



VASO COMBINADO/SIDRA
VERRE A EAU
HIGHBALL GLASS
BICCHIERE COKTAIL
COPO COMBINADO



4001 1016: 520 cc
Pack 6 uds
€: 4,32 / IVA: 5,23



VASO WHISKY
VERRE A WHISKY
WHISKY GLASS
BICCHIERE WHISKY
COPO DE WHISKY



4001 1017: 280 cc
Pack 6 uds
€: 5,20 / IVA: 6,30



VASO PINTA
VERRE A BIÈRE
PINT GLASS
BICCHIERE TUMBLER
COPO DE CONHAQUE



4001 1018: 345 cc
Pack 6 uds
€: 3,90 / IVA: 4,72



COCINA / CUISINE / KITCHEN / CUCINA / COZINHA

Cristalería y Vajilla / Verrerie et vaisselles / Glassware and crockery / Cristalleria e stoviglie / Vidros e louças



Mod. Lublin

VASO AGUA
VERRE A EAU
WATER GLASS
BICCHIERE PER AQUA
COPO DE ÁGUA



4001 1020: 305 cc
Pack 6 uds
€: 5,50 / IVA: 6,65



1

VASO REFRESCO
VERRE A RAFRAÏCHISSEMENT
SOFT-DRINK GLASS
BICCHIERE DA RINFRESCO
COPO DE REFRESCO



4001 1021: 360 cc
Pack 6 uds
€: 5,98 / IVA: 7,24



1

COCINA / CUISINE / KITCHEN / CUCINA / COZINHA

Cristalería y Vajilla / Verrerie et vaisselles / Glassware and crockery / Cristalleria e stoviglie / Vidros e louças



Mod. Orla

TAZA CAFÉ/INFUSIÓN
TASSE A CAFÉ
COFFEE CUP
TAZZA CAFFÈ
CHÁVENA DE CAFÉ



4001 1210: 225 cc
Pack 6 uds
€: 5,76 / IVA: 6,97

1

Mod. Dobra

COPA HELADO
COUPES A GLACES
ICE CREAM CUP
COPPA GELATO
TAÇA DE GELADO



4001 1211: 285 cc
Pack 6 uds
€: 7,56 / IVA: 9,15

1

COCINA / CUISINE / KITCHEN / CUCINA / COZINHA

Accesorios / Accessoires / Accessories / Accessori / Acessórios



Udai

Mod. Marnai, Shiala & Kelna

Las mejores soluciones para mejorar tu despensa y frigorífico con envases de varios tamaños. Guardar, congelar, calentar, servir y comer, destacando en cada momento un perfecto sistema de almacenamiento de alimentos apilable, limpio, higiénico y moderno. Resistentes a los golpes, aptos para el horno, microondas y lavavajillas.

Solutions idéales pour optimiser l'espace dans votre réfrigérateur avec ces emballages de plusieurs tailles. Garder, congeler, réchauffer, servir et manger, permettant à tout moment un stockage parfait dans ces emballages empilables, propres, hygiéniques et modernes. Résistants aux coups, adaptés au four, micro-onde et lave-vaisselle.

The best solutions to optimise the space in your larder and refrigerator with containers of several sizes. They can be used to keep, freeze, heat up and eat food, allowing a perfect storage system which is stackable, clean, hygienic and modern. Shock-resistant and suitable for oven, microwave and dishwasher.

Le migliori soluzioni per migliorare la vostra dispensa e il frigorifero grazie a contenitori di varie dimensioni. Conservare, congelare, riscaldare, servire e mangiare, disponendo in ogni momento di un sistema perfetto di immagazzinamento degli alimenti, il tutto impilabile, pulito, igienico e moderno. Resistenti agli urti, adatti per forno, microonde e lavastoviglie.

As melhores soluções para melhorar a sua despensa e o seu frigorífico com recipientes de vários tamanhos. Guardar, congelar, aquecer, servir e comer, destacando a cada momento um sistema perfeito de armazenamento para empilhar, limpo, higiénico e moderno. Resistente aos golpes, próprio para o forno, micro-ondas e para a máquina de lavar louça.



Mod. Marnai

FIAMBRERA RECTANGULAR TRANSPARENTE
BOITE HERMETIQUE PLAST. RECTANGULAIRE TRANSPARENTE
RECT. TRANSPARENT LUNCH BOX
CONTENITORE RETTANGOLARE TRASPARENTE
CAIXA DE COZINHA TRANSPARENTE

4160 0331: 0,5 l
€: 0,61 / IVA: 0,74
📦 1/12

4160 0332: 1 l
€: 0,92 / IVA: 1,12
📦 1/12

4160 0333: 2,8 l
€: 1,46 / IVA: 1,77
📦 1/12



Mod. Shiala

FIAMBRERA CUADRADA AZUL
BOITE HERMETIQUE PLAST. CARRÉE BLEUE
SQUARE BLUE LUNCH BOX
CONTENITORE QUADRATO BLU
CAIXA DE COZINHA QUADRADA AZUL

4160 0335: 0,5 l
€: 0,61 / IVA: 0,74
📦 1/12

4160 0336: 1 l
€: 0,92 / IVA: 1,12
📦 1/12

4160 0337: 2,8 l
€: 1,46 / IVA: 1,77
📦 1/12



Mod. Kelna

FIAMBRERA HERMÉTICA RECTANGULAR
BOITE HERMÉTIQUE RECT
RECTANGULAR HERMETIC LUNCH BOX
CONTENITORE ERMETICO PER CIBO
CAIXA DE COZINHA HERMETICA RECT.

4160 0341: 0,5 l
€: 1,82 / IVA: 2,21
📦 1/12

4160 0342: 0,75 l
€: 2,00 / IVA: 2,42
📦 1/12

4160 0343: 1,2 l
€: 1,43 / IVA: 1,74
📦 1/12



COCINA / CUISINE / KITCHEN / CUCINA / COZINHA

Accesorios / Accessoires / Accessories / Accessori / Acessórios

ENSALADERA + ESCURREVERDURAS
SALADIER + PASSOIRE
SALAD BOWL+STRAINER
INSALATIERA + SCOLAVERDURA
SALADEIRA + ESCORREDOR



4160 0360:
Ø300x170 mm / 5,7 l
€: 3,02 / IVA: 3,66

1/6

CENTRIFUGADOR LECHUGA
ESSOREUSE A SALADE
SALAD SPINNER
CENTRIFUGA PER INSALATA
CENTRIFUGADORA P/ ALFACE



4160 0361:
Ø270x180 mm / 5,5 l
€: 5,43 / IVA: 6,58

1



ESCURREVERDURAS
PASSOIRE
STRAINER
SCOLAVERDURA
ESCORREDOR DE VEGETAIS



4160 0362V: Ø200mm
€: 0,86 / IVA: 1,05
1/12

4160 0363V: Ø300mm
€: 1,37 / IVA: 1,66
1/12

ESCURREVERDURAS MANGO
PASSOIRE AVEC MANCHE
STRAINER WITH HANDLE
SCOLAVERDURA CON MANICO
ESCORREDOR DE VEGETAIS



4160 0364V: Ø200mm
€: 0,86 / IVA: 1,05
1/12

4160 0365V: Ø300mm
€: 1,37 / IVA: 1,66
1/12

COCINA / CUISINE / KITCHEN / CUCINA / COZINHA

Accesorios / Accessoires / Accessories / Accessori / Acessórios

CUBITERA RELLENABLE
BOITE A GLACONS REMPLISSABLE
REFILABLE ICE CUBE TRAY
FORMA GHIACCIO RICARICABILE
FORMA P/ GELO RECARREGÁVEL

4160 0355:
€: 1,20 / IVA: 1,46

 1/12



CUBITERA FLEXIBLE
SUPPORT A GLACONS FLEXIBLE
FLEXIBLE ICE CUBE TRAY
FORMA GHIACCIO FLESSIBILE
FORMA P/ GELO FLEXIVEL

4160 0356:
€: 1,45 / IVA: 1,76

 1/12



QUESERA REDONDA
BOITE A FROMAGE RONDE
ROUND CHEESE DISH
CONTENITORE FORMAGGIO ROTONDO
QUEIJEIRA REDONDA

4160 0352: Ø245x190 mm
€: 5,05 / IVA: 6,12

 1/12





EMBUDO DE PLÁSTICO
ENTONNOIR PLASTIC
PLASTIC FUNNEL
IMBUTO IN PLASTICA
FUNIL PLÁSTICO

4160 1131: Ø110mm

€: 0,42 / IVA: 0,51

1/12

4160 1133: Ø160mm

€: 0,66 / IVA: 0,80

1/12

4160 1132: Ø130mm

€: 0,54 / IVA: 0,66

1/12

4160 1134: Ø220mm

€: 1,40 / IVA: 1,70

1/12



RALLADOR
RÂPE
GRATER
GRATTUGIA
RALADOR

4160 0373: 275 x 155mm

€: 1,40 / IVA: 1,70

1/12

COCINA / CUISINE / KITCHEN / CUCINA / COZINHA

Accesorios / Accessoires / Accessories / Accessori / Acessórios

TAPA MICROONDAS
COUVERCLE MICRO-ONDES
MICROWAVE COVER
COPERCHIO MICROONDE
TAMPA MICROONDAS

4160 0321: Ø260x80 mm

€: 0,96 / IVA: 1,16

 1/12



PORTATORTILLAS HERMÉTICA + PALA
BOITE HERMETIQUE + PALETTE
SPANISH OMELETTE HOLDER + SLICE
RECIPIENTE HERMETICO PER OMELETTE
RECIPIENTE P/OMELETES HERMÉTICO + PÁ

4160 0292: Ø260x65 mm

€: 4,63 / IVA: 5,61

 1



VUELCATORTILLAS
COUVERCLE OMELETTE
OVER SPANISH OMELETTE TURNER
GIRAFRITTATA
VIRA-OMELETES

4160 0322: Ø290x50 mm

€: 1,27 / IVA: 1,54

 1





TAZA
TASSES A CAFE
CUP
TAZZA
CANECAS

4160 0353: 0,4 l
€: 1,50 / IVA: 1,82

1/12



BANDEJA DE PLÁSTICO
PLATEAU PLASTIQUE
PLASTIC TRAY
VASSOIO IN PLASTICA
BANDEIJA PLÁSTICO

4160 0351: 425x305x50 mm
€: 3,10 / IVA: 3,75

1/12



COCINA / CUISINE / KITCHEN / CUCINA / COZINHA

Accesorios / Accessoires / Accessories / Accessori / Acessórios



Los accesorios de cocina son indispensables para tener todos los utensilios a mano y en orden. Además, ayudan a optimizar el espacio disponible y a proteger encimeras e interiores de armarios. En esta amplia gama de accesorios de cocina se encuentra todo en menaje, complementos, utensilios y elementos auxiliares necesarios actualmente, para hacer de tu cocina un lugar más práctico, cómodo y ordenado con propuestas Cofan Home originales, sobrias y prácticas.

Les accessoires de cuisine sont indispensables et il faut disposer de tous les ustensiles à portée de main et en ordre. Ils aident également à optimiser l'espace disponible et à protéger les portes et les intérieurs des armoires. Dans cette vaste gamme d'accessoires de cuisine nous pouvons trouver tout en ménagère, ustensiles et éléments auxiliaires nécessaires pour faire de la cuisine un lieu pratique, confortable, ordonné, grâce aux produits Cofan Home originaux, sobres et pratiques.

Kitchen accessories are essential to have all utensils on hand and organized. In addition, they help to optimize the available space and to protect worktops and the interior of cupboards. In this broad range of kitchen accessories one can find tableware, utensils, and all those elements that are currently needed to make of your kitchen a useful, comfortable as well as a tidy place. Cofan Home designs are original, restrained and useful.

Gli accessori della cucina sono indispensabili per avere tutti gli utensili a portata di mano e in ordine, aiutando inoltre ad ottimizzare gli spazi. In questa ampia gamma di accessori si trovano stoviglie, utensili e articoli utilizzati normalmente nella propria cucina, rendendola un posto pratico, comodo e ordinato. Il tutto grazie alle proposte di Cofan Home.

Os acessórios de cozinha são indispensáveis para ter todos os utensilios à mão e em ordem. Também ajudam a otimizar o espaço disponível e para proteger as bancadas e os interiores dos armários. Nesta ampla gama de acessórios de cozinha, encontra-se tudo em utensilios de cozinha, acessórios, utensilios e elementos auxiliares necessários para fazer da sua cozinha um lugar mais prático, confortável, bem ordenada, com propostas Cofan Home originais, simples e práticas.



JARRA DE AGUA
PICHET D'EAU
WATER JUG
CARAFFA D'ACQUA
JARRO DE ÁGUA

4160 0222: 2 l
€: 5,00 / IVA: 6,05

1/6



JARRA MEDIDORA TRASLÚCIDA
PICHET GRADUE TRANSPARENT
TRANSLUCENT GAUGE JUG
BROCCA DOSATRICE TRASLUCIDA
JARRO DE MEDIÇÃO TRANSLÚCIDO

4160 0265: 1,2 l
€: 2,73 / IVA: 3,31

1/8



VASO MEDIDOR CON TAPA
VERRE MESUREUR AVEC COUVERCLE
MEASURING JAR WITH TAP
BROCCA DOSATRICE CON COPERCHIO
COPO MEDIDOR COM TAMPA

4160 0310: 0,6 l
€: 2,67 / IVA: 3,24

1/8



COCINA / CUISINE / KITCHEN / CUCINA / COZINHA

Accesorios / Accessoires / Accessories / Accessori / Acessórios

AZUCARERO COCINA
SUCRIER DE CUISINE
KITCHEN SUGAR BOWL
ZUCCHIERA DA CUCINA
AÇUCAREIRO COZINHA

4160 0295:
€: 3,10 / IVA: 3,76

 1/8



SALERO BLANCO
SALIERE BLANCHE
WHITE SALT SHAKER
SALIERA BIANCA
SALEIRO BRANCO

4160 0296:
€: 3,70 / IVA: 4,48

 1/8



EXPRIMIDOR DOS FUNCIONES
PRESSE AGRUMES DEUX FONCTIONS
TWO FUNCTIONS SQUEEZER
SPREMIAGRUMI A DOPPIA FUNZIONE
ESPREMEDOR DUAS FUNÇÕES

4160 0291:
€: 2,70 / IVA: 3,27

 1/12



PORTARROLLOS DE COCINA SOBREMESA
ROULEAU NAPPE DE CUISINE
KITCHEN ROLL HOLDER
PORTAROTOLI DA CUCINA
SUPORTE ROLO PAPEL COZINHA

4160 0251:
€: 6,70 / IVA: 8,11

1/6



PORTARROLLOS COCINA UNITARIO
PORTE-COUVERTS CUISINE UNITAIRE
ONE UNIT KITCHEN ROLL HOLDER
PORTAROTILI DA CUCINA
UMA UNIDADE SUPORTE DE ROLO COZINHA

4160 0272:
€: 2,63 / IVA: 3,19

1/12



COCINA / CUISINE / KITCHEN / CUCINA / COZINHA

Accesorios / Accessoires / Accessories / Accessori / Acessórios

PORTARROLLOS COCINA TRIPLE
SUPPORT ROULEAU TRIPLE DE CUISINE
TRIPLE KITCHEN ROLL HOLDER
PORTAROTOLI DA CUCINA TRIPLO
TRIPLO SUPORTE ROLOS COZINHA

4160 0257:

€: 10,05 / IVA: 12,17

 1



PORTACUBIERTOS COLOR BLANCO
PORTE COUVERTS BLANC
WHITE CUTLERY TRAY
PORTAPOSATE DI COLORE BIANCO
ORGANIZADOR DE TALLERES BRANCO

4160 0271: 360x330x53 mm

€: 3,62 / IVA: 4,39

 1/12



SERVILLETERO BÁSICO DE PLÁSTICO
BASIC PLASTIC SERVIETTE HOLDER
PORTE SERVIETTES BASIC PLASTIQUE
PORTATOVAGLIOLI SEMPLICE, IN PLASTICA
PORTA-GUARDANAPOS BÁSICO PLÁSTICO

4160 0372:
€: 2,10 / IVA: 2,55

📦 1/16



SERVILLETERO PLÁSTICO
PORTE SERVIETTES PLASTIQUE
PLASTIC SERVIETTE HOLDER
PORTATOVAGLIOLI IN PLASTICA
PORTA-GUARDANAPOS PLÁSTICO

4160 0371: 275x150x50 mm
€: 2,95 / IVA: 3,57

📦 1



COCINA / CUISINE / KITCHEN / CUCINA / COZINHA

Accesorios / Accessoires / Accessories / Accessori / Acessórios

CARRITO MULTIUSOS 3 CESTAS
CHARRIOT MULTIUSAGE 3 PANIERS
MULTIPURPOSE TROLLEY, 3 BASKETS
CARRELLO MULTIUSO VERDURA, 3 RIPIANI
CARRINHO MULTIUSO 3 CESTAS

4160 0206: 440 x 300 x 640 mm

€: 19,30 / IVA: 23,36

 1/6



TABLA CORTAFIAMBRES
TABLEAU PETIT FORMAT
CHOPPING BOARD
TAGLIERE
TÁBUA DE CORTAR

4160 0285: 250x150 mm

€: 2,66 / IVA: 3,22

 1/12

4160 0287: 350x250 mm

€: 5,52 / IVA: 6,68

 1/12

4160 0286: 300x200 mm

€: 3,57 / IVA: 4,32

 1/12



ESCURREPLATOS + BANDEJA
EGOUTTOIR + PLATEAU
DISH RACK + TRAY
SCOLAPIATTI + VASSOIO
ESCORREDOR DE PRATOS + BANDEJA

4160 0288: 380x475 mm
€: 7,90 / IVA: 9,56

1/6



SALVAPLATOS CUADRADO
DESSOUS DE PLAT CARRÉ
SQUARE SINK MAT
SALVALAVELLI QUADRATO
PANO DE PRATO QUADRADO

4160 0311: 315x315 mm
€: 2,10 / IVA: 2,55

1/25



SALVAPLATOS REDONDO
DESSOUS DE PLAT ROND
ROUND SINK MAT
SALVALAVELLI TONDO
PANO DE PRATO REDONDO

4160 0312: Ø345 mm
€: 2,45 / IVA: 2,97

1/25

NEW



COCINA / CUISINE / KITCHEN / CUCINA / COZINHA

Paelleras / Poêles à paella / Paella pans / Padelle per Paella / Paelheira

EXPOSITOR PARA PAELLAS
PRESENTOIR DE POÊLES À PAELLA
DISPLAY STAND FOR PAELLA PANS
ESPOSITORE PAELLERA
EXPOSITOR DE PAELHEIRAS

EXPOSITOR23: 182 x 82 cm
€: 122,45 / IVA: 148,17

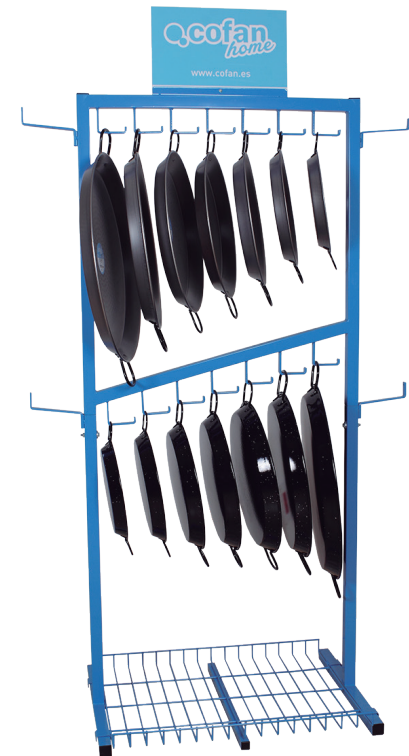
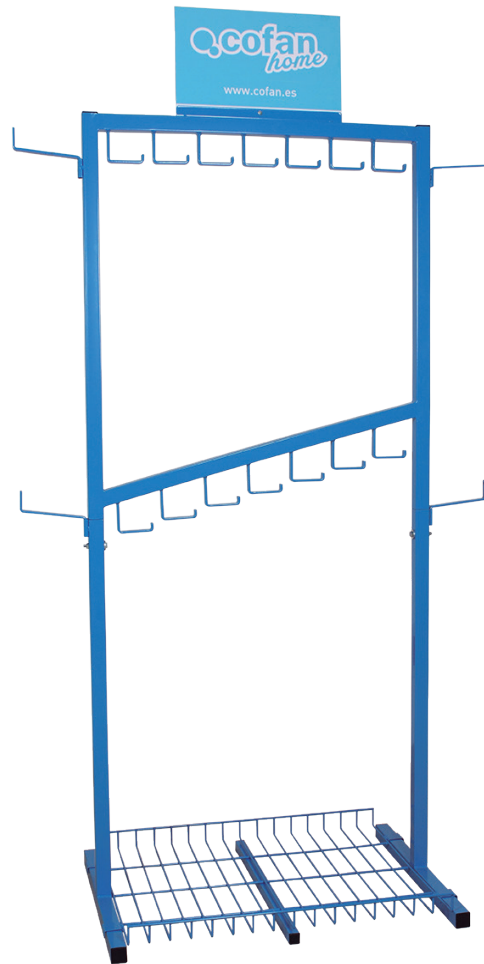

Se suministra sin paelleras.

COCINA / CUISINE / KITCHEN / CUCINA / COZINHA

Accesorios / Accessoires / Accessories / Accessori / Acessórios



Base de Polipropileno TNT tejido sin tejer y soporte de PVC estampado.
Rollo de 1,40 x 25 m de longitud. Made in Spain.

Base en Polypropylène TNT tissu non tissé et support en PVC imprimé.
Rouleau de 1,40 x 25 m de longueur. Made in Spain.

Polypropylene based, non-woven fabric and printed PVC coating.
Roll measures: 1,40 x 25 m long. Made in Spain.

Base in Polipropilene, tessuto non tessuto (TNT) e supporto in PVC impresso.
Rotola da 1,40 m x 25 m di lunghezza. Made in Spain.

Base de Polipropileno TNT não tecido e suporte de PVC estampado.
Rolo de 1,40 x 25 m de comprimento. Made in Spain.

Mod. Fiorentina



ROLLO SEMIHULE BÁSICO
ROULEAU BULGOMME BASIQUE
OILCLOTH ROLL BASIC
ROTOLO GOMMA BASE
ROLO PLÁSTICO BASICO

4100 4201:
€: 53,50 / IVA: 64,74

Mod. Dalby

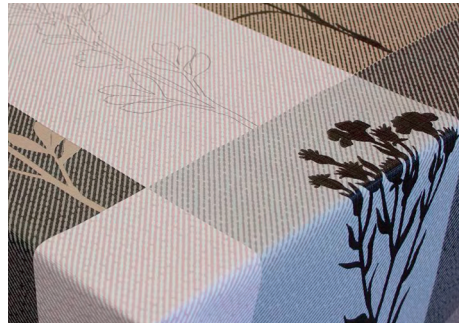

ROLLO SEMIHULE BÁSICO
ROULEAU BULGOMME BASIQUE
OILCLOTH ROLL BASIC
ROTOLO GOMMA BASE
ROLO PLÁSTICO BASICO

4100 4202:
€: 53,50 / IVA: 64,74

Mod. Retro

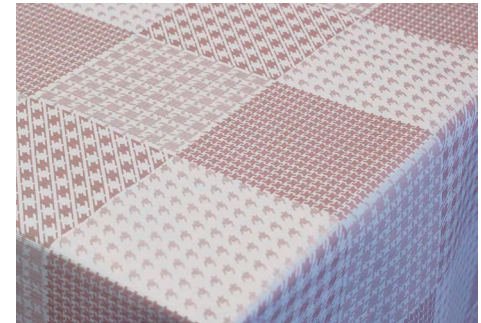

ROLLO SEMIHULE BÁSICO
ROULEAU BULGOMME BASIQUE
OILCLOTH ROLL BASIC
ROTOLO GOMMA BASE
ROLO PLÁSTICO BASICO

4100 4203:
€: 53,50 / IVA: 64,74



Antimanchas
Anti-tache
Stain resistant
Antimacchia
Antimancha

Mod. Garden



ROLLO SEMIHULE BÁSICO
ROULEAU BULGOMME BASIQUE
OILCLOTH ROLL BASIC
ROTOLO GOMMA BASE
ROLO PLÁSTICO BASICO

4100 4204:
€: 53,50 / IVA: 64,74

Mod. Heda



ROLLO SEMIHULE BÁSICO
ROULEAU BULGOMME BASIQUE
OILCLOTH ROLL BASIC
ROTOLO GOMMA BASE
ROLO PLÁSTICO BASICO

4100 4205:
€: 53,50 / IVA: 64,74

Mod. Capuccino



ROLLO SEMIHULE BÁSICO
ROULEAU BULGOMME BASIQUE
OILCLOTH ROLL BASIC
ROTOLO GOMMA BASE
ROLO PLÁSTICO BASICO

4100 4206:
€: 53,50 / IVA: 64,74

COCINA / CUISINE / KITCHEN / CUCINA / COZINHA

Accesorios / Accessoires / Accessories / Accessori / Acessórios



Base de Polipropileno TNT tejido sin tejer y soporte de PVC estampado.
Rollo de 1,40 x 25 m de longitud. Made in Spain.

Base en Polypropylène TNT tissu non tissé et support en PVC imprimé.
Rouleau de 1,40 x 25 m de longueur. Made in Spain.

Polypropylene based, non-woven fabric and printed PVC coating.
Roll measures: 1,40 x 25 m long. Made in Spain.

Base in Polipropilene, tessuto non tessuto (TNT) e supporto in PVC impresso.
Rotola da 1,40 m x 25 m di lunghezza. Made in Spain.

Base de Polipropileno TNT não tecido e suporte de PVC estampado.
Rolo de 1,40 x 25 m de comprimento. Made in Spain.

Mod. Vegan



ROLLO SEMIHULE BÁSICO
ROULEAU BULGOMME BASIQUE
OILCLOTH ROLL BASIC
ROTOLO GOMMA BASE
ROLO PLÁSTICO BASICO

4100 4207:

€: 53,50 / IVA: 64,74

Mod. Topes



ROLLO SEMIHULE BÁSICO
ROULEAU BULGOMME BASIQUE
OILCLOTH ROLL BASIC
ROTOLO GOMMA BASE
ROLO PLÁSTICO BASICO

4100 4208:

€: 53,50 / IVA: 64,74



Base de algodón sin tejer y soporte de PVC estampado.
Rollo de 1,40 x 25 m de longitud. Made in Spain.

Base en coton non tissée et support en PVC imprimé.
Rouleau de 1,40 x 25 m de longueur. Made in Spain.

Non-woven cotton base and printed PVC coating.
Roll measures: 1,40 x 25 m long. Made in Spain.

Base in cotone TNT e supporto in PVC impresso.
Rotola da 1,40 m x 25 m di lunghezza. Made in Spain.

Base de algodão, não tecido e suporte de PVC estampado.
Rolo de 1,40 x 25 m de comprimento. Made in Spain.



Antimanchas
Anti-tache
Stain resistant
Antimacchia
Antimancha

Mod. Atlantic



ROLLO SEMIHULE ALGODÓN
ROULEAU BULGOMME COTON
OILCLOTH ROLL COTTON
OILCLOTH ROLL COTTON
ROLO PLÁSTICO ALGODÃO

4100 4301:
€: 93,00 / IVA: 112,53

Mod. Vivaldi



ROLLO SEMIHULE ALGODÓN
ROULEAU BULGOMME COTON
OILCLOTH ROLL COTTON
OILCLOTH ROLL COTTON
ROLO PLÁSTICO ALGODÃO

4100 4302:
€: 93,00 / IVA: 112,53

Mod. Seattle



ROLLO SEMIHULE ALGODÓN
ROULEAU BULGOMME COTON
OILCLOTH ROLL COTTON
OILCLOTH ROLL COTTON
ROLO PLÁSTICO ALGODÃO

4100 4303:
€: 93,00 / IVA: 112,53

COCINA / CUISINE / KITCHEN / CUCINA / COZINHA

Accesorios / Accessoires / Accessories / Accessori / Acessórios



Base de algodón sin tejer y soporte de PVC estampado.
Rollo de 1,40 x 25 m de longitud. Made in Spain.

Base en coton non tissée et support en PVC imprimé.
Rouleau de 1.40 x 25 m de longueur. Made in Spain.

Non-woven cotton base and printed PVC coating.
Roll measures: 1,40 x 25 m long. Made in Spain.

Base in cotone TNT e supporto in PVC impresso.
Rotola da 1,40 m x 25 m di lunghezza. Made in Spain.

Base de algodão, não tecido e suporte de PVC estampado.
Rolo de 1,40 x 25 m de comprimento. Made in Spain.

Mod. Romantic Letters



ROLLO SEMIHULE ALGODÓN
ROULEAU BULGOMME COTON
OILCLOTH ROLL COTTON
OILCLOTH ROLL COTTON
ROLO PLÁSTICO ALGODÃO

4100 4304:

€: 93,00 / IVA: 112,53

Mod. Patchwork



ROLLO SEMIHULE ALGODÓN
ROULEAU BULGOMME COTON
OILCLOTH ROLL COTTON
OILCLOTH ROLL COTTON
ROLO PLÁSTICO ALGODÃO

4100 4305:

€: 93,00 / IVA: 112,53

Mod. Cuori



ROLLO SEMIHULE ALGODÓN
ROULEAU BULGOMME COTON
OILCLOTH ROLL COTTON
OILCLOTH ROLL COTTON
ROLO PLÁSTICO ALGODÃO

4100 4306:

€: 93,00 / IVA: 112,53



Antimanchas
Anti-tache
Stain resistant
Antimacchia
Antimancha

Mod. Cupcakes



ROLLO SEMIHULE ALGODÓN
ROULEAU BULGOMME COTON
OILCLOTH ROLL COTTON
OILCLOTH ROLL COTTON
ROLO PLÁSTICO ALGODÃO

4100 4307:
€: 93,00 / IVA: 112,53

Mod. Nueva Escocia

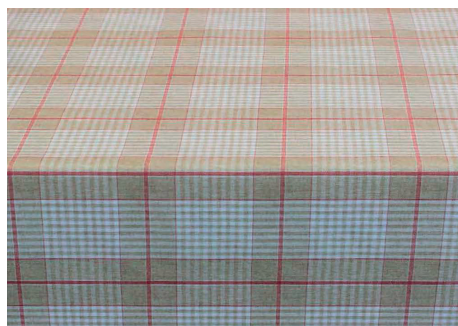

ROLLO SEMIHULE ALGODÓN
ROULEAU BULGOMME COTON
OILCLOTH ROLL COTTON
OILCLOTH ROLL COTTON
ROLO PLÁSTICO ALGODÃO

4100 4308:
€: 93,00 / IVA: 112,53

Mod. Lavanda

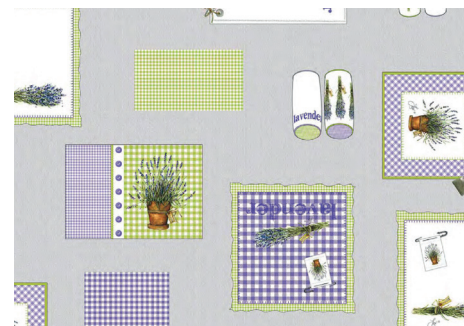

ROLLO SEMIHULE ALGODÓN
ROULEAU BULGOMME COTON
OILCLOTH ROLL COTTON
OILCLOTH ROLL COTTON
ROLO PLÁSTICO ALGODÃO

4100 4309:
€: 93,00 / IVA: 112,53

COCINA / CUISINE / KITCHEN / CUCINA / COZINHA

Accesorios / Accessoires / Accessories / Accessori / Acessórios



50% algodón y 50% poliéster. Estampado, tratamiento polímeros de resina acrílica más antimanchas. Rollo de 1,40 x 25 m de longitud. Made in Spain.

50% coton et 50% polyester. Impression, traitement polymères de résine acrylique et antitaches. Rouleau de 1.40 x 25 m de longueur. Made in Spain.

50% cotton and 50% polyester. Printed, acrylic resin polymer treatment and stain resistant. Roll measures: 1.40 x 25 m long. Made in Spain.

50% cotone e 50% poliestere. Impresso, trattamento con polimeri di resina acrilica antimacchia. Rotola da 1,40 m x 25 m di lunghezza. Made in Spain.

50% algodão e 50% poliéster. Estampado, Tratamento de polímeros de resina acrílica mais anti-manchas. Rolo de 1,40 x 25 m de comprimento. Made in Spain.

Mod. Royal Gris

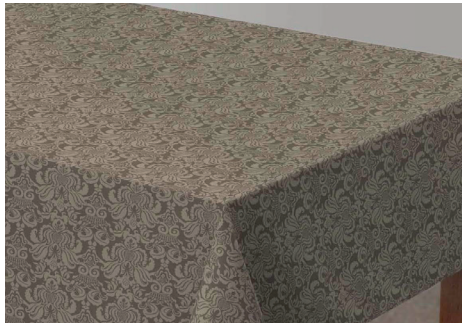

ROLLO HULE
ROULEAU BULGOMME
STAIN RESISTANT OIL CLOTH ROLL
ROTOLO GOMMA
ROLO PLÁSTICO

4100 4401:
€: 142,25 / IVA: 172,13

Mod. Royal Beige

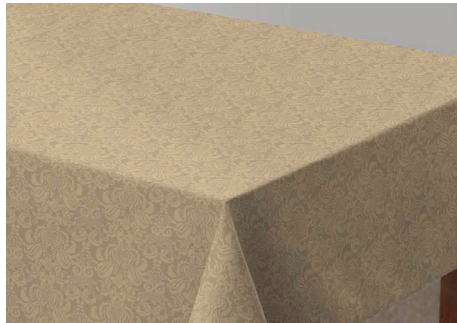

ROLLO HULE
ROULEAU BULGOMME
STAIN RESISTANT OIL CLOTH ROLL
ROTOLO GOMMA
ROLO PLÁSTICO

4100 4402:
€: 142,25 / IVA: 172,13

Mod. Miró



ROLLO HULE
ROULEAU BULGOMME
STAIN RESISTANT OIL CLOTH ROLL
ROTOLO GOMMA
ROLO PLÁSTICO

4100 4403:
€: 142,25 / IVA: 172,13



Antimanchas
Anti-tache
Stain resistant
Antimacchia
Antimancha

Mod. Fiorella



ROLLO HULE
ROULEAU BULGOMME
STAIN RESISTANT OIL CLOTH ROLL
ROTOLO GOMMA
ROLO PLÁSTICO

4100 4404:
€: 142,25 / IVA: 172,13

Mod. Tamariz



ROLLO HULE
ROULEAU BULGOMME
STAIN RESISTANT OIL CLOTH ROLL
ROTOLO GOMMA
ROLO PLÁSTICO

4100 4405:
€: 142,25 / IVA: 172,13

Mod. Frutal



ROLLO HULE
ROULEAU BULGOMME
STAIN RESISTANT OIL CLOTH ROLL
ROTOLO GOMMA
ROLO PLÁSTICO

4100 4406:
€: 142,25 / IVA: 172,13

● BAÑO / SALLE DE BAIN
BATHROOM / BAGNO
CASA DE BANHO

●
108

Accesorios
Accessoires
Accessories
Accessori
Acessórios

●
122

Alfombras de baño
Tapis de bain
Bathroom rug
Tappetino bagno
Tapete banho



BAÑO / SALLE DE BAIN / BATHROOM / BAGNO / CASA DE BANHO

Accesorios / Accessoires / Accessories / Accessori / Acessórios



La ducha y el baño se convierten en nuevas sensaciones Cofan Home. En cada uno de los artículos para la ducha se encierran varias posiciones como lluvia, intensa, espuma, masaje o combinados, para disfrutar de auténticos momentos de relax. Además, cuenta con sistemas integrados de ahorro de agua. Los accesorios de baño y ducha Cofan Home, cambian la habitación más pequeña del hogar en una zona excepcional para la relajación y el cuidado personal.

La douche et le bain sont transformés grâce aux nouvelles sensations CofanHome, chaque article de douche permet plusieurs positions comme le jet en pluie, le jet concentré, le jet moussant, le jet massant ou combinés, pour profiter d'authentiques moments de relaxation. Grâce aux systèmes intégrés d'économie d'eau, les accessoires bain de Cofanhome expert, transforment la pièce la plus petite de la maison en un lieu exceptionnel, dédié à la relaxation et au bien être.

Shower and bath turn into new CofanHome sensations. Every hand-held shower heads enables the adjustment of several positions such as rain, heavy rain, foam, massage or a combination to enjoy authentic moments of relaxation. CofanHome bathroom accessories, with integrated systems to save water, turn the smallest room in the house into an outstanding place to relaxation and personal care.

Grazie a CofanHome il bagno raggiunge nuove piacevoli sensazioni. La doccia, grazie agli articoli presenti, diventa un momento di puro relax. Lasciatevi conquistare dalle differenti tipologie di getto disponibili e dai sistemi integrati di risparmio dell'acqua. Gli accessori per bagno e doccia CofanHome cambiano il modo di percepire il bagno rendendolo una zona eccezionale per il relax e la propria cura personale.

O chuveiro e o banheiro convertem-se em novas sensações CofanHome, em cada um dos artigos para o chuveiro existem várias posições como chuva, intensa, espuma, massagem ou combinações para desfrutar momentos autênticos de relaxamento. Com sistemas integrados de poupança de água os acessórios do banho Cofanhome e chuveiro, alteram o quarto mais pequeno da casa em uma área excepcional para relaxamento e cuidados pessoais.



KIT DUCHA 3 FUNCIONES
DOUCHE 3 FONCTIONS
SHOWER SET 3 FUNCTIONS
DOCCETTA 3 FUNZIONI
KIT DUCHE 3 FUNCOES

Mango + Flexo + Colgador
 Pommeau + Support + Flexible
 Handle + Hose + Hanger
 Doccetta + Gancio + Tubo
 Mang + Telfone + Suporte

4200 1132:
 €: 7,83 / IVA: 9,47

1/48



KIT DUCHA 1 FUNCIÓN
DOUCHE 1 FONCTION
SHOWER SET 1 FUNCTION
DOCCETTA 1 FUNZIONE
KIT DUCHE 1 FUNCOES

Mango + Flexo + Colgador
 Pommeau + Support + Flexible
 Handle + Hose + Hanger
 Doccetta + Gancio + Tubo
 Mang + Telfone + Suporte

4200 1133:
 €: 8,48 / IVA: 10,26

1/48



KIT DUCHA 5 FUNCIONES
DOUCHE 5 FONCTIONS
SHOWER SET 5 FUNCTIONS
DOCCETTA 5 FUNZIONI
KIT DUCHE 5 FUNCOES

Mango + Flexo + Colgador
 Pommeau + Support + Flexible
 Handle + Hose + Hanger
 Doccetta + Gancio + Tubo
 Mang + Telfone + Suporte

4200 1134:
 €: 10,28 / IVA: 12,44

1/48

BAÑO / SALLE DE BAIN / BATHROOM / BAGNO / CASA DE BANHO

Accesorios / Accessoires / Accessories / Accessori / Acessórios



MANGO DUCHA CROMADO, 5 FUNCIONES
POMMEAU DE DOUCHE ABS, 5 FONCTIONS
ABS HAND SHOWER, 5 FUNCTIONS
DOCCETTA IN ABS, 5 FUNZIONI
CHUVEIRO DE MÃO ABS, 5 FUNÇÕES

4200 1121:
€: 5,20 / IVA: 6,30

1/48



MANGO DUCHA CROMADO, 3+2 FUNCIONES
POMMEAU DE DOUCHE ABS, 3+2 FONCTIONS
ABS HAND SHOWER, 3+2 FUNCTIONS
DOCCETTA IN ABS, 3+2 FUNZIONI
CHUVEIRO DE MÃO ABS, 3+2 FUNÇÕES

4200 1122:
€: 4,73 / IVA: 5,73

1/48



MANGO DUCHA CROMADO, 1 FUNCIÓN
POMMEAU DE DOUCHE ABS, 1 FONCTION
ABS HAND SHOWER, 1 FUNCTION
DOCCETTA IN ABS, 1 FUNZIONE
CHUVEIRO DE MÃO ABS, 1 FUNÇÃO

4200 1123:
€: 2,64 / IVA: 3,19

1/48



INOX

FLEXO DUCHA INOXIDABLE EXTENSIBLE
FLEXIBLE EN ACIER INOXYDABLE CHROMÉ
STAINLESS STEEL CHROMED HOSE
TUBO CROMATO IN ACCIAIO INOSSIDABILE
MANGUEIRA DE AÇO INOXIDÁVEL CROMADO

4200 1101: 1,5 m
€: 4,83 / IVA: 5,84

1/48



FLEXO DUCHA PVC PLATA/LATÓN
FLEXIBLE PVC
PVC HOSE, SILVER/BRASS
TUBO IN PVC ARGENTO/OTTONE
MANGUEIRA DE PVC PRATA/BRONZE

4200 1102: 1,5 m
€: 4,20 / IVA: 5,09

1/48



FLEXO DUCHA PVC/LATÓN COLOR BLANCO
FLEXIBLE PVC
WHITE PVC HOSE, BRASS NUT & CORE
TUBO IN PVC DADO E CORPO IN OTTONE
MANGUEIRA DE PVC PORCA E NÚCLEO DE BRONZE

4200 1103: 1,5 m
€: 2,92 / IVA: 3,53

1/48

BAÑO / SALLE DE BAIN / BATHROOM / BAGNO / CASA DE BANHO

Accesorios / Accessoires / Accessories / Accessori / Acessórios



Daura

Mod. Daura

Los accesorios de baño Daura de Cofan Home son la unión de la sencillez, las formas y la funcionalidad. Surtido esencial para cualquier baño, diseñados para adecuarse a cualquier espacio y necesidad. Inspirados en formas clásicas y caracterizados por su gran versatilidad. Reúne líneas de soluciones ideadas para pequeñas y grandes zonas de baño, con fáciles instalaciones y amplia duración en el tiempo.

Accessoires pour le bain Daura de CofanHome, apportent simplicité, charme des formes et fonctionnalité. Assortiment essentiel pour toute salle de bain conçu pour s'adapter à chaque espace et à toutes nécessités. Inspirés de la tendance classique et caractérisés par sa grande versatilité, ils sont conçus pour les petites et grandes salles de bain, sont faciles à utiliser et offrent une longue durée d'utilisation.

Bathroom accessories "Daura" from CofanHome combining simplicity, usefulness and forms. A selection of the most essential items for any bathroom to suit any space and need. They are inspired in classic forms because of their versatility, providing appropriate solutions to small and big bathrooms. Long-lasting and easy use.

Gli accessori per il bagno della linea Daura della CofanHome uniscono la semplicità alla funzionalità grazie a un assortimento di accessori per qualsiasi bagno, specificamente progettati per adattarsi a qualsiasi spazio e necessità grazie alle proprie forme classiche e a caratteristiche che li rendono versatili sia per piccole, sia per ampie zone del bagno. Sono di facile installazione e godono di un'ampia durata nel tempo.

Acessórios para o banho, Daura de CofanHome, a união da simplicidade, formas e funcionalidade. Sortido essencial para qualquer banheiro concebido para se adaptar a qualquer espaço e necessidade. Inspirada no clássico e caracterizada pela sua grande versatilidade, traz uma linha de soluções concebidas para as zonas pequenas e grandes do banho, com fácil instalação e grande duração no tempo.



Mod. Daura



PORTARROLLOS DE BAÑO
SUPPORT ROULEAU PAPIER TOILETTE
TOILET ROLL HOLDER
PORTAROTOLI PER BAGNO "DAURA"
SUPORTE DE ROLO DE BANHO

4200 1301:
€: 6,37 / IVA: 7,71

1/6



JABONERA
PORTE SAVON
SOAP DISH
PORTASAPONE
SABONETEIRA

4200 1302:
€: 5,90 / IVA: 7,14

1/6



PORTACEPILLOS CON VASO
SUPPORT BROUSSE A DENT AVEC VERRE
TOOTHBRUSH HOLDER WITH CUP
BICCHIERE PORTASPAZZOLINO
SUPORTE COM COPO P/ ESCOVA DE DENTES

4200 1303:
€: 6,70 / IVA: 8,11

1/6

Mod. Daura

ARO TOALLERO
SUPPORT SERVIETTE DE TOILETTE
TOWEL RING
PORTASALVIETTE AD ANELLO
ARO DE TOALHA

4200 1304:
€: 7,19 / IVA: 8,70

 1/6



PERCHA COLGADOR
PATERE
HANGER
GANCIO APPENDIABITI
GANCHO P/ PENDURAR

4200 1305:
€: 3,35 / IVA: 4,05

 1/6



Mod. Daura



BARRA TOALLERO
BARRE PORTE SERVIETTE
TOWEL BAR
PORTASALVIETTE
BARRA P/ TOALHA

4200 1306:
€: 6,65 / IVA: 8,05

 1/6



REPISA BAÑO
ÉTAGÈRE BAIN
BATHROOM SHELF
MENSOLA BAGNO
PRATELEIRA BANHO

4200 1307:
€: 12,42 / IVA: 15,03

 1/6

BAÑO / SALLE DE BAIN / BATHROOM / BAGNO / CASA DE BANHO

Accesorios / Accessoires / Accessories / Accessori / Acessórios



La estancia del baño debe ser algo más que el lugar donde el aseo personal sea cotidiano. Es la zona Cofan Home donde abordar el día a día, aplicarse una ducha bajo el grifo, arreglarse para una cita, compartir espejo o donde hacer alguna purificación a las prendas más delicadas.

La salle de bain représente le lieu de soin et de bien être de la maison. Plus qu'une pièce sanitaire, c'est désormais un espace où il fait bon passer du temps, où la journée commence, où l'on se prépare pour un rendez-vous, où l'on partage un miroir, où l'on s'isole comme dans un cocon accueillant, propice à des instants de détente.

The bathroom must be something much more than the place used for habits of personal hygiene. It is the place where the day begins, where one can enjoy taking a shower, get ready for a date, share mirror with someone or wash delicate garments.

Il bagno è il luogo in cui si cura la propria igiene quotidiana e in cui si affronta la giornata: dove farsi una doccia, dove prepararsi per un appuntamento. CofanHome mette a disposizione accessori per riporre e organizzare oggetti; per pulire il proprio bagno e specchi.

O quarto de banho deve ser algo mais do que o lugar onde é diária a higiene pessoal. É a zona CofanHome onde começa o dia-a-dia, onde tomar banho debaixo do chuveiro, onde arranjar-se para um encontro, onde partilhar um espelho ou onde vestir peças mais delicadas.

**CESTILLO MULTIUSOS
PANIER MULTIUSAGES
HANGING BASKET
CESTINO MULTIUSO
CESTA MULTIUSOS**

4200 1226: 260x85x260 mm

€: 2,30 / IVA: 2,79

1/12



**ESTANTE VENTOSAS MULTIUSOS
ÉTAGÈRE VENTOUSES MULTIUSAGES
MULTIPURPOSE SUCTION CUP SHELF
MENSOLA MULTIUSO A VENTOSA
PRATELEIRA COM VENTOSAS MULTIUSOS**

4200 1225: 270x130x95 mm

€: 4,65 / IVA: 5,61

1/6



BAÑO / SALLE DE BAIN / BATHROOM / BAGNO / CASA DE BANHO

Accesorios / Accessoires / Accessories / Accessori / Acessórios



ESPEJO REDONDO
MIROIR ROND
ROUND MIRROR
SPECCHIO ROTONDO
ESPELHO REDONDO

4200 1231: Ø600mm
€: 21,12 / IVA: 25,56

 1/4



ESPEJO RECTANGULAR
MIROIR RECTANGULAIRE
RECTANGULAR MIRROR
SPECCHIO RETTANGOLARE
ESPELHO RETANGULAR

4200 1232: 550 x 650 x 40 mm
€: 22,37 / IVA: 27,06

 1/4



RINCONERA BAÑO ESTRELLA
ETAGERE D'ANGLE SALLE DE BAIN
STAR BATHROOM CORNER SHELF
MENSOLA ANGOLARE BAGNO
PRATELEIRA DE CANTO BANHO ESTRELA

4200 1223: 230 x 230 x 570 mm
€: 15,09 / IVA: 18,26

 1/4



RINCONERA DUCHA
ETAGERE D'ANGLE DOUCHE
SHOWER CORNER SHELF
MENSOLA DOCCIA
PRATELEIRA BANHO

4200 1224: 160 x 160 x 700 cm
€: 10,25 / IVA: 12,40

 1/4

BAÑO / SALLE DE BAIN / BATHROOM / BAGNO / CASA DE BANHO

Accesorios / Accessoires / Accessories / Accessori / Acessórios



TABURETE DE BAÑO 3 PATAS
TABOURET SALLE DE BAIN
BATHROOM STOOL
SGABELLO DA BAGNO
BANCO DE BANHO

4200 1221:
€: 15,83 / IVA: 19,16

 1/6



BANQUETA MULTIUSOS BLANCA
BANC MULTIUSAGES
MULTIPURPOSE STOOL
SGABELLO MULTIUSO
BANCO MULTIUSOS

4200 1222:
€: 9,96 / IVA: 12,06

 1/6



TAPA W.C UNIVERSAL
ABATTANT WC
TOILET SEAT
COPERCHIO PER IL VASO DEL GABINETTO
TAMPA SANITA

4200 1202:
€: 17,75 / IVA: 21,48

1/6



ESCOBILLERO DE RINCONERA BLANCO
BROSSE WC ANGLE
CORNER TOILET BRUSH
PORTASCPINO AD ANGOLO DEL WC
ESCOVA SANITÁRIA P/CANTO

4200 1211:
€: 3,45 / IVA: 4,18

1/6



ESCOBILLERO COMPLETO BASIC BLANCO
BROSSE À WC
TOILET BRUSH
PORTASCPINO DEL WC
PIASSABA

4200 1212:
€: 2,56 / IVA: 3,10

1/12

BAÑO / SALLE DE BAIN / BATHROOM / BAGNO / CASA DE BANHO

Alfombras de baño / Tapis de bain / Bathroom rug / Tappetino bagno / Tapete banho



Drip

Mod. Drip

Alfombras antideslizantes en varios colores y tamaños, ideales para baño y ducha. Proporcionan seguridad e higiene para toda la familia al tener propiedades anti-moho y anti-hongos. Es posible cortar a la medida adecuada y se adhiere a todo tipo de suelos y diversidad de superficies.

Tapis antidérapants disponibles en plusieurs coloris et plusieurs tailles, idéales pour bain et douche, fournissant sécurité et hygiène pour toute la famille avec ses propriétés anti-moisissure et anti-humidité. Peut être coupé à la dimension appropriée, adhère à tout type de sols et de surfaces.

Non-slip bathroom rugs available in several colours and sizes, suitable for bathtubs and showers and providing safety and hygiene to all the family because of their anti-mould and antifungal properties. Possibility to cut a suitable measure and they adhere to any kind of floor or surface.

Tappetini bagno antiscivolo, di vari colori e misure. Ideali per bagno e doccia, forniscono sicurezza e igiene per tutta la famiglia. Hanno proprietà antifungo e antimuffa. È possibile ridurre con facilità la loro dimensione, aderiscono a tutti i tipi di suolo e alle differenti superfici.

Tapetes antiderrapantes em várias cores e tamanhos ideais para o banho e chuveiro, proporcionando segurança e higiene para toda a família ao ter propriedades anti-mofo e anti-fungos. É possível cortar a medida adequada e adere-se a todos os tipos de solos e medi de superfícies diversas.



PVC



750 x 360 mm

- 4200 1411A:
€: 6,90 / IVA: 8,35
📦 1/10
- 4200 1411B:
€: 7,14 / IVA: 8,64
📦 1/10
- ⊘ 4200 1411T:
€: 7,14 / IVA: 8,64
📦 1/10

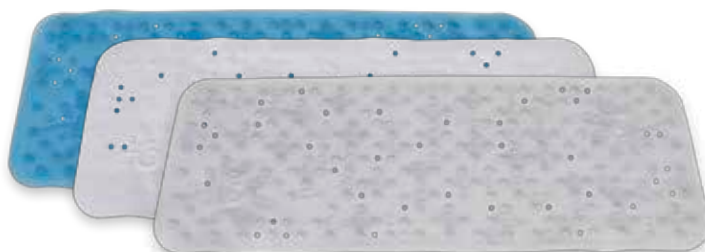

950 x 360 cm

- 4200 1412A:
€: 8,17 / IVA: 9,89
📦 1/10
- 4200 1412B:
€: 8,78 / IVA: 10,62
📦 1/10
- ⊘ 4200 1412T:
€: 8,44 / IVA: 10,21
📦 1/10



530 x 530 cm

- 4200 1413A:
€: 6,68 / IVA: 8,08
📦 1/10
- 4200 1413B:
€: 7,00 / IVA: 8,46
📦 1/10
- ⊘ 4200 1413T:
€: 7,20 / IVA: 8,72
📦 1/10

LIMPIEZA / NETTOYAGE CLEANING / PULIZIA / LIMPEZA

126

Tablas de planchar

Table à repasser

Ironing boards

Assi da stiro

Tabua de engomar

136

Fundas de sustitución

Housse pour table a repasser

Ironing board covers

Rivestimenti assi da stiro

Cobertura para tábua de engomar

142

Tendederos

Etendoirs

Airers

Stendibiancheria

Estendais

146

Articulos de limpieza

Articles de nettoyage

Cleaning items

Articoli per la pulizia

Artigos de limpeza



LIMPIEZA / NETTOYAGE / CLEANING / PULIZIA / LIMPEZA

Tablas de planchar / Table à repasser / Ironing boards / Assi da stiro / Tabua de engomar



Salerno

Mod. Salerno

La tabla de planchar modelo "Salerno" es eficiente y económica. Cuenta con soporte para plancha de vapor, rejilla especial resistente a la oxidación y posibilidad de ajustar a varias alturas. Disponible en distintos estampados.

Table à repasser modèle "Salerno" efficaces et économiques avec support pour plaque vapeur, grille spéciale résistante à l'oxydation et possibilité de réglage sur plusieurs hauteurs, disponible en différentes impressions.

Ironing board "Salerno", an efficient and economical model with a stand for steam iron, a special rust resistant frame and possibility to adjust it at several height positions. Available in different prints.

Asse da stiro modello "Salerno", efficiente ed economica, con supporto per il ferro a vapore. Griglia speciale resistente all'ossidazione e regolabile a diverse altezze. Disponibili con stampe differenti.

Tabua de engomar, modelo eficiente e econômica "Salerno" com suporte para ferro a vapor, grade especial resistente à oxidação e ajustável a diferentes alturas, disponível em diferentes padrões.



Mod. Salerno

TABLA DE PLANCHAR
TABLE À REPASSER
IRONING BOARD
L'ASSE DA STIRO
TABUA DE PASSAR

110 x 32 cm



4100 4104.2
€: 19,30 / IVA: 23,36

1



4100 4104.5
€: 19,30 / IVA: 23,36

1



4100 4104.8
€: 19,30 / IVA: 23,36

1



4100 4104
€: 19,30 / IVA: 23,36

1

LIMPIEZA / NETTOYAGE / CLEANING / PULIZIA / LIMPEZA

Tablas de planchar / Table à repasser / Ironing boards / Assi da stiro / Tabua de engomar

Mod. Cesena

Tabla de planchar modelo "Cesena", con bandeja especial para centros de planchado y varias posiciones en altura mediante una cómoda palanca lateral, permitiendo que el planchado sea lo más sencillo posible.

Table à repasser modèle "Cesena" avec plateau spécial pour centrale vapeur et plusieurs positions de hauteur au moyen d'un levier latéral très commode, permettant le repassage est le plus simple possible.

Ironing board "Cesena" model with a special tray for steam generator irons. By means of a comfortable lever it is possible to adjust several height positions allowing a simple way to iron.

Asse da stiro modello "Cesena" con piastra laterale speciale e altezza regolabile a diverse altezze, tramite una comoda leva laterale. Consente di stirare nella maniera più semplice possibile.

Tábua de engomar, modelo "Cesena" com a bandeja especial para engomarmos centros e várias posições de altura por uma alavanca lateral confortável, permitindo que o engomar seja o mais simples possível.



Cesena

Mod. Cesena

TABLA DE PLANCHAR
TABLE À REPASSER
IRONING BOARD
L'ASSE DA STIRO
TABUA DE PASSAR

120 x 36 cm



4100 4105
€: 33,75 / IVA: 40,85

1



4100 4105.3
€: 33,75 / IVA: 40,85

1



4100 4105.4
€: 33,75 / IVA: 40,85

1



4100 4105.2
€: 33,75 / IVA: 40,85

1

LIMPIEZA / NETTOYAGE / CLEANING / PULIZIA / LIMPEZA

Tablas de planchar / Table à repasser / Ironing boards / Assi da stiro / Tabua de engomar



Tivoli

Mod. Tivoli

Tabla de planchar modelo "Tivoli", con bandeja especial para centro de planchado, patas estabilizadoras anti-movimiento y varias posiciones para la altura del usuario, con tamaño XL ideal para prendas grandes, sábanas y manteles.

Table à repasser modèle "Tivoli" avec plateau spécial pour centrale vapeur, pieds stabilisateurs et plusieurs positions pour la hauteur confortable pour l'utilisateur taille XL idéal pour les grandes pièces et les nappes.

Ironing board "Tivoli" model with a special tray for steam generator irons, stabilizing legs that avoid the movement and several height positions enabling the adjustment to the user height and an XL size ideal for large clothes, bed sheets and tablecloths.

Asse da stiro modello "Tivoli" con piastra laterale speciale, con piedini antiscivolo. Altezza regolabile a diverse altezze in funzione dell'altezza dell'utilizzatore. Dimensione XL, ideale per stirare lenzuola e tovaglie di grosse dimensioni.

Tábua de engomar, modelo "Tivoli" com a bandeja especial para engomar nos centros, patas estáveis e anti-movimento e várias posições de altura do usuário, com tamanho XL ideal para peças grandes, lençóis e toalhas.

Mod. Tivoli

TABLA DE PLANCHAR
TABLE À REPASSER
IRONING BOARD
L'ASSE DA STIRO
TABUA DE PASSAR

125 x 41 cm



4100 4106.0
€: 38,60 / IVA: 46,70

1

4100 4106.7
€: 38,60 / IVA: 46,70

1



4100 4106
€: 38,60 / IVA: 46,70

1

LIMPIEZA / NETTOYAGE / CLEANING / PULIZIA / LIMPEZA

Tablas de planchar / Table à repasser / Ironing boards / Assi da stiro / Tabua de engomar

Mod. Vittoria

Tabla de planchar modelo "Vittoria", con bandeja especial plegable para centros de planchado, patas curvadas anti-movimiento, especiales para planchar sentados y de pie. Posibilidad de regular a varias alturas. Con anchos de 47 cm es posible el planchado de las prendas más grandes y pesadas.

Table à repasser modèle "Vittoria" avec plateau spécial pliant pour centrales vapeur, pieds incurvés anti-mouvement spéciaux pour repasser assis et debout. Possibilité de régler à plusieurs hauteurs. Large de 47 cm, son plateau permet de repasser des articles grands et lourds.

Ironing board "Vittoria" model with a special tray for steam generator irons, curved legs avoiding movement and suitable for ironing while you are sitting or standing. Possibility to adjust at several heights. Its 47-cm width makes possible the ironing of the largest and heaviest clothes.

Asse da stiro modello "Vittoria" con piastra laterale pieghevole. Piedini ricurvi antiscivolo per stirare seduti e in piedi. Possibilità di regolare le varie altezze. Con spessore di 47 cm, è possibile stirare oggetti più grandi e pesanti.

Tábua de engomar, modelo "Vittoria" com a bandeja especial para engomar nos centros, patas curvadas e anti-movimento especiais para poder engomar sentado ou de pé. Possibilidade de regular várias posições de alturas. Com largura de 47 cm é possível passar as peças mais grandes e pesadas.



Vittoria

Mod. Vittoria

TABLA DE PLANCHAR
TABLE À REPASSER
IRONING BOARD
L'ASSE DA STIRO
TABUA DE PASSAR

130 x 47 cm



4100 4107
€: 45,80 / IVA: 55,41

📦 1



4100 4107.9
€: 45,80 / IVA: 55,41

📦 1



4100 4107.10
€: 45,80 / IVA: 55,41

📦 1



4100 4107.11
€: 45,80 / IVA: 55,41

📦 1



4100 4107.12
€: 45,80 / IVA: 55,41

📦 1

LIMPIEZA / NETTOYAGE / CLEANING / PULIZIA / LIMPEZA

Tablas de planchar / Table à repasser / Ironing boards / Assi da stiro / Tabua de engomar



Mod. Toscana

Tabla de planchar "Mod. Toscana" con medidas de 113 x 34 cm. Tabla de planchar plegable con recubrimiento especial electrostático, baño especial para evitar la corrosión y apoyos en el suelo antideslizantes.

Table à repasser "Mod. Toscan", dimensions 113 x 34 cm Table à repasser pliable avec recouvrement spécial électrostatique, bain spécial pour éviter la corrosion et pieds antidérapants.

Ironing board "Toscana" model. Measures: 113 x 34 cm. Foldable ironing board with a special electrostatic coating to prevent from corrosion and nonslip feet.

Asse da stiro "Mod. Toscana" con misure da 113 x 34 cm. Asse da stiro pieghevole con rivestimento speciale elettrostatico, rivestimento speciale anticorrosione e piedini antiscivolo.

Tábua de engomar "Mod. Toscana" com medidas 113 x 34 cm. Tábua de passar dobrável com revestimento especial eletroestático. banho especial para evitar a corrosão e apoios no piso antiderrapantes.



4100 4101
€: 20,70 / IVA: 25,05

 1

LIMPIEZA / NETTOYAGE / CLEANING / PULIZIA / LIMPEZA

Fundas de sustitución / Housse pour table a repasser / Ironing board covers / Rivestimenti assi da stiro / Cobertura para tábua de engomar



Fundas de sustitución para tablas de planchar resistentes y duraderas. Las coberturas de sustitución de Cofan Home están disponibles en una amplia variedad de diseños, tamaños y patrones. La mejor opción adaptable a cualquier tabla de planchar, con la plataforma de red o de metal. Disponibles en 100% algodón, acolchadas con espuma o muletón, según modelos.

Housses de remplacement pour tables à repasser résistantes et durables, housses Cofanhome disponibles dans une vaste variété de modèles et de tailles. Adaptable à toutes les tables à repasser avec plate-forme filet ou métal. 100% coton, rembourrée avec mousse ou molleton en fonction des modèles.

Long-lasting and resistant ironing board covers Cofanhome available in a wide range of designs, sizes and patterns. The best option that fits any ironing board with metallic or mesh platform. Available in 100% cotton or padded with foam or flanellette depending on the model.

Rivestimenti per assi da stiro, resistenti e durevoli nel tempo. I rivestimenti CofanHome sono disponibili in un'ampia varietà di disegni, formati e modelli. La migliore opzione adattabile a qualsiasi asse da stiro, con piattaforma in rete o metallo. Disponibile in 100% cotone, imbottitura in schiuma o flanella di cotone a seconda del modello.

Coberturas de substituição das tábuas de engomar resistentes e duráveis, as coberturas de substituição de Cofanhome estão disponíveis em uma ampla variedade de modelos, tamanhos e padrões. A melhor opção adaptável a qualquer tábua de passar com a plataforma de rede ou de metal. Disponíveis em 100% algodão, acolchoadas com espuma ou lã dependendo dos modelos.

ALGODÓN
COTON
COTTON
COTONE
ALGODÃO

120 x 40 cm



4100 4115
€: 5,07 / IVA: 6,13



4100 4115.3
€: 5,07 / IVA: 6,13



4100 4115.5
€: 5,07 / IVA: 6,13



LIMPIEZA / NETTOYAGE / CLEANING / PULIZIA / LIMPEZA

Fundas de sustitución / Housse pour table a repasser / Ironing board covers / Rivestimenti assi da stiro / Cobertura para tábua de engomar

ALGODÓN
COTON
COTTON
COTONE
ALGODÃO

120 x 40 cm



4100 4115.6
€: 5,07 / IVA: 6,13



4100 4115.7
€: 5,07 / IVA: 6,13



4100 4115.8
€: 5,07 / IVA: 6,13



4100 4115.13
€: 5,07 / IVA: 6,13



ALGODÓN
COTON
COTTON
COTONE
ALGODÃO

120 x 40 cm



4100 4115.14
€: 5,07 / IVA: 6,13



4100 4115.15
€: 5,07 / IVA: 6,13



4100 4115.17
€: 5,07 / IVA: 6,13



ALGODÓN
COTON
COTTON
COTONE
ALGODÃO

135 x 53 cm



4100 4116
€: 5,18 / IVA: 6,27



4100 4116.8
€: 5,18 / IVA: 6,27



LIMPIEZA / NETTOYAGE / CLEANING / PULIZIA / LIMPEZA

Fundas de sustitución / Housse pour table a repasser / Ironing board covers / Rivestimenti assi da stiro / Cobertura para tábua de engomar

ALGODÓN
COTON
COTTON
COTONE
ALGODÃO

140 x 60 cm



4100 4117
€: 6,03 / IVA: 7,30

1



4100 4117.3
€: 6,03 / IVA: 7,30

1



4100 4117.11
€: 6,03 / IVA: 7,30

1

ACOLCHADAS
REMBOURRÉ
MOLLETON
IMBOTTITO
ACOLCHOADO

135 x 53 cm

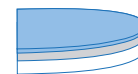

4100 4118
€: 7,00 / IVA: 8,47

1



4100 4118.8
€: 7,00 / IVA: 8,47

1

ACOLCHADAS
REMBOURRÉ
MOLLETON
IMBOTTITO
ACOLCHOADO

140 x 60 cm

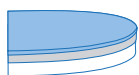

4100 4119
€: 8,20 / IVA: 9,92



4100 4119.3
€: 8,20 / IVA: 9,92



4100 4119.12
€: 8,20 / IVA: 9,92



4100 4119.14
€: 8,20 / IVA: 9,92



LIMPIEZA / NETTOYAGE / CLEANING / PULIZIA / LIMPEZA

Tendederos / Etendoirs / Airers / Stendibiancheria / Estendais



Tendederos Cofan Home plegables y basculantes con varias posiciones posibles, con recubrimiento especial antioxidante y electroestático, con modelos con bolsas central para las pinzas de ropa.

Etendoirs Cofan Home pliables et basculants avec plusieurs positions possibles, recouvrement spécial antioxydant et électrostatique, disposant d'une sacoche centrale pour les pinces à linge.

Cofan Home airers, foldable and with several positions. Special antirust and electrostatic coating. These models have small cloth bag in the middle to keep the clothes pegs.

Stendibiancheria Cofan Home pieghevoli e con varie posizioni possibili, con rivestimento speciale antiossidante ed elettrostatico. Modelli provvisti di portamollette in posizione centrale.

Estendais Cofan Home dobráveis e basculantes com várias posições possíveis, com revestimento especial antioxidante e eletroestático, com modelos com sacos centrais para as molas da roupa.

TENEDERO PLEGABLE
ETENDOIR A LINGE PLIABLE
FOLDING CLOTHES FRAME
STENDIBIANCHERIA PIEGHEVOLE
ESTENDAL FLEXIVEL

Mod. Riviera



4100 4121: 14 m
€: 12,00 / IVA: 14,52

📦 1/6

Mod. Imperia



4100 4122: 20 m
€: 17,30 / IVA: 20,14

📦 1/5

LIMPIEZA / NETTOYAGE / CLEANING / PULIZIA / LIMPEZA

Tendederos / Etendoirs / Airers / Stendibiancheria / Estendais



PACK 24 UDS PINZAS MADERA PRIMERA CALIDAD
PACK 24 UNITÉS PINCES A LINGE EN BOIS PREMIÈRE QUALITÉ
PACK 24 UDS WOODEN CLOTHES PEGS TOP QUALITY
CONFEZIONE DA 24 PZ. MOLLETTE LEGNO PRIMA QUALITÀ
EMBALAGEM 24 PÇS PRENDEDORES MADEIRA PRIMEIRA QUALIDADE

4100 4151: 70 mm
Pack 24 uds - €: 1,20 / IVA: 1,46

 1/135

PACK 24 UDS PINZAS PLÁSTICO ESTÁNDAR
PACK 24 UNITÉS PINCES A LINGE EN PLASTIQUE STANDARD
PACK 24 UDS PLASTIC CLOTHES PEGS STANDARD
CONFEZIONE DA 24 PZ. MOLLETTE IN PLASTICA, STANDARD
EMBALAGEM 24 PÇS PRENDEDORES PLÁSTICO STANDARD

4100 4152: 70 mm
Pack 24 uds - €: 0,92 / IVA: 1,12

 1/210



PACK 12 UDS PINZAS PLÁSTICO GIGANTE
PACK 12 UNITES PINCES A LINGE PLASTIQUE GÉANTE
PACK 12 PCS PLASTIC CLOTHES PEGS GIANT
CONFEZIONE DA 12 PZ. MOLLETTE IN PLASTICA, GIGANTI
EMBALAGEM 12 PÇS PRENEDORES PLÁSTICO GIGANTE

4100 4153: 90 mm
 Pack 12 uds - €: 1,16 / IVA: 1,41

1/240



CESTA DE PINZAS
PANIER POUR EPINGLE A LINGE
CLOTHES PEG BASKET
CESTA BUCATO
CESTO P/ MOLAS

4160 1108: 250x180x100 mm
 €: 1,15 / IVA: 1,40

1/12

LIMPIEZA / NETTOYAGE / CLEANING / PULIZIA / LIMPEZA

Artículos de limpieza / Articles de nettoyage / Cleaning items / Articoli per la pulizia / Artigos de limpeza



Cepillos y escobas de barrer domésticos con fibras de PVC suaves, en múltiples colores y algunas unidades con protectores laterales. Posibilidades de uso en interiores, exteriores, moquetas, pisos delicados, jardines, etc.

Brosses et balai pour usage domestiques avec fibres en PVC lisse, disponible en plusieurs couleurs et quelques unités avec des protecteurs latéraux, idéal pour intérieur, extérieur, moquette, sols délicats, jardins, etc..

Scrubbing brushes and brooms with soft PVC fibres in several colours. Some of them have side protectors, possibility of use indoors, outdoors, fitted carpets, delicate floors, gardens, etc.

Scope e spazzole per pulizia domestica, fibre in PVC morbido e di differenti colorazioni. Disponibili alcuni prodotti con protezione laterale. Possibilità di uso interno, esterno, moquette, pavimenti delicati, giardini, ecc.

Escovas e vassouras de varrer domésticas com fibra de PVC, macias e em várias cores e algumas unidades com proteção lateral, possibilidades de uso em interiores, exteriores, tapetes, pisos delicados, jardins, etc.

CEPILLO DE BARRER BASIC
BROSSE A BALAI BASIQUE
BASIC SWEEPING BRUSH
SCOPA
VASSOURA BÁSICA



Mod. Galit

4100 3110: 250 x 47 x 87 mm
€: 1,20 / IVA: 1,46

📦 1/12



Mod. Adama

4100 3111: 265 x 47 x 105 mm
€: 2,00 / IVA: 2,43

📦 1/12

LIMPIEZA / NETTOYAGE / CLEANING / PULIZIA / LIMPEZA

Articulos de limpieza / Articles de nettoyage / Cleaning items / Articoli per la pulizia / Artigos de limpeza

CEPILLO BARRER CON PROTECTORES
BROSSE A BALAI AVEC PROTECTIONS
SWEEPING BRUSH WITH PROTECTOR
SCOPA CON PROTEZIONE ALLA BASE
VASSOURA COM PROTECTOR



Mod. Yemina

4100 3112: 275 x 53 x 110 mm
€: 2,60 / IVA: 3,15

 1/12

ESCOBA DE BARRER
BALAI
SWEEPING BROOM
SCOPA
VASSOURA



Mod. Arusa

4100 3113: 250 x 25 x 240 mm
€: 2,70 / IVA: 3,27

 1/12

CEPILLO DE BARRER EXTERIORES
BROSSE A BALAI EXTERIEURS
SWEEPING BRUSH FOR OUTDOOR USE
SCOPA PER USO ESTERNO
VASSOURA P/EXTERIOR



Mod. Orel

4100 3114: 270 x 47 x 125 mm
€: 2,97 / IVA: 3,59

📦 1/6

PALO PLASTIFICADO AZUL/NEGRO
MANCHE A BALAI PLASTIQUE BLEU/NOIR
BLUE/BLACK PLASTIFIED HANDLE
MANICO PLASTIFICATO BLU/NERO
PAU PLASTIFICADO AZUL/PRETO



4100 3120: 1,40 m (Ø25mm)
€: 0,82 / IVA: 1,00

📦 1/12

PALO PINTADO AZUL ALU-PRO
MANCHE A BALAI ALU-PRO BLEU
BLUE PAINTED ALU-PRO HANDLE
MANICO VERNICIATO BLU-PRO
PAU PINTADO AZUL ALU-PRO



4100 3121: 1,40 m (Ø32mm)
€: 1,60 / IVA: 1,93

📦 1/12

LIMPIEZA / NETTOYAGE / CLEANING / PULIZIA / LIMPEZA

Articulos de limpieza / Articles de nettoyage / Cleaning items / Articoli per la pulizia / Artigos de limpeza



Mod. Ronen

CUBO•ESCURRIDOR NEGRO
SCEAU A ESSORAGE NOIR
BLACK BUCKET WITH WRINGER
SECCHIO•STRIZZATORE NERO
BALDE•ESPRESSADOR PRETO



4100 3130: 13 l
€: 2,73 / IVA: 3,31

 1/6

Mod. Hadar

CUBO+ESCURRIDOR ROJO
SCEAU A ESSORAGE ROUGE
RED BUCKET WITH WRINGER
SECCHIO+STRIZZATORE ROSSO
BALDE+ESPRESSADOR VERMELHO



4100 3131: 13 l
€: 7,11 / IVA: 8,61

📦 1/6

Mod. Amir

CUBO+ESCURRIDOR AZUL
SCEAU A ESSORAGE BLEU
BLUE BUCKET WITH WRINGER
SECCHIO+STRIZZATORE BLU
BALDE+ESPRESSADOR AZUL



4100 3132: 13 l
€: 4,80 / IVA: 5,80

📦 1/6

Mod. Kalil

CUBO+ESCURRIDOR OVAL AZUL
SCEAU A ESSORAGE BLEU OVALE
OVAL BLUE BUCKET WITH WRINGER
SECCHIO+STRIZZATORE BLU OVALE
BALDE+ESPRESSADOR AZUL OVAL



4100 3133: 15 l
€: 3,72 / IVA: 4,50

📦 1/6

LIMPIEZA / NETTOYAGE / CLEANING / PULIZIA / LIMPEZA

Artículos de limpieza / Articles de nettoyage / Cleaning items / Articoli per la pulizia / Artigos de limpeza

FREGONA ALGODÓN
SERPILLERE COTON
COTTON MOP
MOCIO COTONE
ESFREGONA ALGODÃO



4100 3150: 180 g
€: 1,14 / IVA: 1,38
📦 1/24

4100 3151: 250 g
€: 1,37 / IVA: 1,66
📦 1/24

FREGONA HILO MICROFIBRA BLANCA
SERPILLERE A FILS MICROFIBRE
WHITE MICROFIBER MOP
MOCIO FILO MICROFIBRA
ESFREGONA FIO MICROFIBRA



4100 3152: 160 g
€: 2,27 / IVA: 2,75
📦 1/24

FREGONA HILO MICROFIBRA BICOLOR
SERPILLERE A FILS MICROFIBRE
MICROFIBER MOP
MOCIO FILO MICROFIBRA
ESFREGONA FIO MICROFIBRA



4100 3156: 160 g
€: 2,70 / IVA: 3,27
📦 1/24

FREGONA TIRAS MICROFIBRA VERDE
SERPILLERE A FILS MICROFIBRE
GREEN MICROFIBER MOP
MOCIO FILO MICROFIBRA
ESFREGONA FIO MICROFIBRA



4100 3157: 155 g
€: 3,04 / IVA: 3,68
📦 1/24

Mod. Siman

RECOGEDOR CON GOMA
PELLE PLASTIQUE
DUSTPAN WITH RUBBER
PALETTA CON GOMMA
PÁ DO LIXO COM BORRACHA



4100 3140:
€: 2,22 / IVA: 2,69

📦 1/18

Mod. Tamar

RECOGEDOR METAL EXTRA
PELLE METAL EXTRA
EXTRA METAL DUSTPAN
PALETTA METALLO EXTRA
PÁ DO LIXO METAL EXTRA



4100 3141:
€: 7,79 / IVA: 9,42

📦 1/6

Mod. Eidan

RECOGEDOR BASIC
PELLE BASIQUE
BASIC DUSTPAN
PALETTA BASICA
PÁ DO LIXO BÁSICA



4100 3142:
€: 1,28 / IVA: 1,55

📦 1/24

LIMPIEZA / NETTOYAGE / CLEANING / PULIZIA / LIMPEZA

Artículos de limpieza / Articles de nettoyage / Cleaning items / Articoli per la pulizia / Artigos de limpeza

CEPILLO FREGAR PLASTIC ONDULADO
BALAI BROSSE PLASTIQUE ONDULÉ
HAND SCRUBBING BRUSH PLASTIC WAVY
SPAZZOLONE IN PLASTICA
ESCOVA DE ESFREGAR PLÁSTICA ONDULADA



0930 1121: 7x4
€: 0,72 / IVA: 0,88

1/24

CEPILLO BUQUE PLASTIC ONDULADO
BALAI BROSSE DE MATELOT PLASTIQUE ONDULÉ
DECK SCRUB BRUSH PLASTIC WAVY
SPAZZOLONE IN PLASTICA CON FORO
ESCOVA DE ESFREGAR CHÃO PLÁSTICO ONDULADO



0930 1122: 5x10
€: 1,59 / IVA: 1,93

1/24

Los limpiacristales Cofan Home cuentan con mangos y goma de alta calidad. Ideal para temperaturas frías y adaptables, tanto a superficies irregulares como a grandes superficies lisas.

Les lave-vitres Cofanhome disposent de manche et caoutchouc de grande qualité, idéal par temps froid et adaptables sur des surfaces irrégulières comme des surfaces lisses.

Cofanhome squeegees have high quality handles and rubbers, ideal for cold temperatures and adaptable to both irregular surfaces or large and smooth surfaces.

Le spazzole Cofanhome sono dotate di manici e gomma ad alta qualità. Ideali per temperature fredde e adattabili sia per superfici irregolari così come grandi superfici lisce.

Os Limpa-Vidros cofan home têm pegas e borracha de alta qualidade, ideal para temperaturas frias e adaptáveis tanto a superfícies irregulares como a grandes superfícies lisas.

LIMPIA CRISTALES METAL
RACLETTE LAVE VITRE
METAL SQUEEGEE
SPAZZOLA LAVAVETRI IN METALLO
LIMPA VIDROS METAL



0930 1381: 200 mm / Ø25 mm
€: 1,90 / IVA: 2,30

 1/10

LIMPIEZA / NETTOYAGE / CLEANING / PULIZIA / LIMPEZA

Artículos de limpieza / Articles de nettoyage / Cleaning items / Articoli per la pulizia / Artigos de limpeza

El cepillo o escobilla limpia botellas es imprescindible para tener las botellas, dedicadas a decoración o al rellenado, listas y limpias antes de su llenado.

Le goupillon permet de nettoyer les bouteilles, il est indispensable pour les bouteilles consacrées à la décoration ou celles que l'on remplit.

The bottle brush is essential in order to have clean and ready bottles used for decorative or refilling purposes.

Il piumino è essenziale per la pulizia e per tenere decorazioni sempre pulite e recipienti pronti all'uso.

A escova de garrafa é essencial para ter as garrafas limpas e prontas para decoração ou para enchê-las.

CEPILLO VARILLA LIMPIA BOTELLAS
GOUPILLON TIGE POUR LE NETTOYAGE DES BOUTEILLES
BOTTLE BRUSH
PIUMINO DA SPOLVERO PER BOTTIGLIE
ESCOVA P/ LIMPAR GARRAFAS



0930 1385: 470 mm
€: 1,10 / IVA: 1,34

 1/12

Plumero de plumas Avestruz, con mangos fabricados en madera. Las plumas de avestruz son aptas para la limpieza en los lugares más complicados y delicados.

Plumeau en plumes d'autruche, avec manche en bois. Les plumes d'autruche sont appropriée pour le nettoyage des zones compliquées et sensibles.

Ostrich feather duster with wooden handles. Ostrich feathers are suitable for cleaning hard-to-reach areas or fragile objects.

Spolverino in piume di struzzo, con manici fabbricati in legno. Le piume sono adatte per la pulizia in posizioni di difficile accesso e su oggetti delicati.

Espanadores de penas de Avestruz, com pegas em madeira. As penas de avestruz são adequadas para a limpeza dos locais mais complicados e sensíveis.

PLUMERO AVESTRUZ MADERA LARGO
PLUMEAU AUTRUCHE BOIS GRAND FORMAT
FEATHER DUSTER OSTRICH WOOD (LONG)
SPOLVERINO IN PIUME DI STRUZZO, MANICO IN LEGNO LUNGO
ESPANADOR AVESTRUZ MADEIRA LONGO



0930 1391: 800 mm
 €: 4,12 / IVA: 4,99

1/12

PLUMERO AVESTRUZ MADERA EXTRA
PLUMEAU AUTRUCHE BOIS FORMAT EXTRA
FEATHER DUSTER OSTRICH WOOD (EXTRA)
SPOLVERINO IN PIUME DI STRUZZO, MANICO IN LEGNO
ESPANADOR AVESTRUZ MADEIRA EXTRA



0930 1392: 550 mm
 €: 5,04 / IVA: 6,10

1/12

LIMPIEZA / NETTOYAGE / CLEANING / PULIZIA / LIMPEZA

Artículos de limpieza / Articles de nettoyage / Cleaning items / Articoli per la pulizia / Artigos de limpeza

BAYETA CRISTALES PERFORADA
TORCHON PERFORÉ POUR LES VITRES
PERFORATED CLOTH FOR GLASS
PANNO CRISTALLI PERFORATO
PANO CRISTAIS PERFURADO

4100 3211: 380 x 380 mm

€: 2,22 / IVA: 2,69

 1/48



BAYETA MULTIUSOS MICROPLUS
TORCHON MULTI-USAGES MICROPLUS
MICROPLUS MULTI-PURPOSE CLOTH
PANNO MULTI-USAGES MICROPLUS
PANO MULTIUSOS MICROPLUS

4100 3221: 400 x 400 mm

€: 1,98 / IVA: 2,40

 1/48



PACK BAYETA RAPID MULTIUSOS (2 UDS)
PACK TORCHONS MULTI-USAGES RAPID 2 UNITÉS
PACK OF RAPID MULTI-PURPOSE CLOTHS, 2PCS
CONFEZIONE PANNI RAPIDI MULTIUSO 2PZ
PACK PANOS MULTIUSOS RAPID 2 UNIDS

4100 3231: 400 x 380 mm

Pack 2 uds - €: 2,29 / IVA: 2,78

 1/24



PACK BAYETA MICROFIBRA (3 UDS)
PACK TORCHONS MICROFIBRE 3 UNITÉS
MICROFIBER CLOTH 3 UNITS PACK
CONFEZIONE PANNO MICROFIBRA 3PZ
PACK PANO MICROFIBRA 3 UNIDS

4100 3241: 300 x 320 mm
Pack 3 uds - €: 1,93 / IVA: 2,34

 1/36



BAYETA MICROTEx
TORCHON MICROTEx
MICROTEx CLOTH
PANNO MICROTEx
PANO DE MICROTEx

4100 3251: 400 x 400 mm
€: 1,13 / IVA: 1,37

 1/24



LIMPIEZA / NETTOYAGE / CLEANING / PULIZIA / LIMPEZA

Articulos de limpieza / Articles de nettoyage / Cleaning items / Articoli per la pulizia / Artigos de limpeza

DESATASCADOR FUELLE GRANDE
DEBOUCHEUR GRAND SOUFFLET
PLUNGER, BIG BELLOWS
STURATORE, GRANDI DIMENSIONI
DESENTUPIDOR FOLE GRANDE



4160 0230:
€: 1,04 / IVA: 1,26

1/12



CUBO BASURA CON PEDAL
POUBELLE A PÉDALE
PEDAL BIN
PATTUMIERA CON PEDALE
BALDE DO LIXO COM PEDAL



4160 0305: 27 l
€: 15,15 / IVA: 18,35

1

CUBO CON PEDAL
PUBELLE SANITARE A PEDALE
TRASH BIN CON PEDAL
SCCHIO CON PEDALE PER IL GABINETTO
BALDE PEDAL SANITA



4160 1205: 7 l
€: 10,15 / IVA: 12,28

1/4

CUBO BASURA PLÁSTICO
POUBELLE CONTAINER PLASTIQUE
PLASTIC TRASH BIN
CONTENITORE IMMONDIZIA IN PLASTICA
BALDE DO LIXO PLÁSTICO



4160 1117: 21 l
€: 4,70 / IVA: 5,70

 1/6

CUBO BASURA ASAS METAL
POUBELLE CONTAINER FERMETURE METAL
TRASH BIN, METAL HANDLES
CONTENITORE IMMONDIZIA, MANICI IN METALLO
BALDE DO LIXO PEGAS METAL



4160 1118: 50 l
€: 12,66 / IVA: 15,31

 1

LIMPIEZA / NETTOYAGE / CLEANING / PULIZIA / LIMPEZA

Artículos de limpieza / Articles de nettoyage / Cleaning items / Articoli per la pulizia / Artigos de limpeza



PAPELERA BASCULANTE
POUBELLE A BASCULE
SWING TRASH BIN
PATTUMIERA BASCULANTE
PAPELEIRA BASCULANTE



● 4160 1105A: 1,9 l • 13 x 12 x 25 cm
€: 1,91 / IVA: 2,31
📦 1/12

● 4160 1105B: 1,9 l • 13 x 12 x 25 cm
€: 1,91 / IVA: 2,31
📦 1/12



● 4160 1106A: 1,1 l • 13 x 12 x 17 cm
€: 1,67 / IVA: 2,02
📦 1/12

● 4160 1106B: 1,1 l • 13 x 12 x 17 cm
€: 1,67 / IVA: 2,02
📦 1/12

PAPELERA BASCULANTE
POUBELLE A BASCULE
SWING TRASH BIN
PATTUMIERA BASCULANTE
PAPELEIRA BASCULANTE



○ 4160 1104B: 15 l · 29 x 25 x 45 cm
€: 9,05 / IVA: 10,95

📦 1



● 4160 1104G: 15 l · 29 x 25 x 45 cm
€: 9,05 / IVA: 10,95

📦 1

LIMPIEZA / NETTOYAGE / CLEANING / PULIZIA / LIMPEZA

Artículos de limpieza / Articles de nettoyage / Cleaning items / Articoli per la pulizia / Artigos de limpeza

Mod. Udai

BARREÑO AZUL
BASSINE BLEUE
BLUE WASH BOWL
CATINO BLU
BACIA AZUL



4160 1121: 3 l
€: 0,92 / IVA: 1,12
📦 1/12

4160 1122: 6 l
€: 1,50 / IVA: 1,81
📦 1/12

4160 1123: 10 l
€: 2,51 / IVA: 3,04
📦 1/12

4160 1124: 15 l
€: 3,11 / IVA: 3,77
📦 1/12

4160 1125: 25 l
€: 4,54 / IVA: 5,50
📦 1/12

4160 1126: 50 l
€: 9,62 / IVA: 11,64
📦 1/12

CUBO PLASTIC ASA METAL
SEAU PLASTIQUE ANSE MÉTAL
PLASTIC BUCKET, METAL HANDLE
SECCHIO IN PLASTICA, MANICO IN METALLO
BALDE PLÁSTICO PEGA METAL



4160 1111: 6 l
€: 1,26 / IVA: 1,53
📦 1/24

4160 1112: 8 l
€: 1,60 / IVA: 1,94
📦 1/24

4160 1113: 12 l
€: 1,95 / IVA: 2,36
📦 1/24

4160 1114: 16 l
€: 3,03 / IVA: 3,67
📦 1/24

Mod. Udai

MATAMOSCAS 2 UDS
TAPETTES A MOUCHES
FLY SWATTER, 2 UNITS
PALETTA PER INSETTI, 2 PZ
MATA-MOSCAS 2 UNID



4160 1109:
Pack 2 uds - €: 0,96 / IVA: 1,16

2/12

NEW



COCINA / CUISINE / KITCHEN / CUCINA / COZINHA

Paelleras / Poêles à paella / Paella pans / Padelles per Paella / Paelheira

EXPOSITOR PARA PAELLAS
PRESENTOIR DE POÊLES À PAELLA
DISPLAY STAND FOR PAELLA PANS
ESPOSITORE PAELLERA
EXPOSITOR DE PAELHEIRAS

EXPOSITOR23: 182 x 82 cm
€: 122,45 / IVA: 148,17

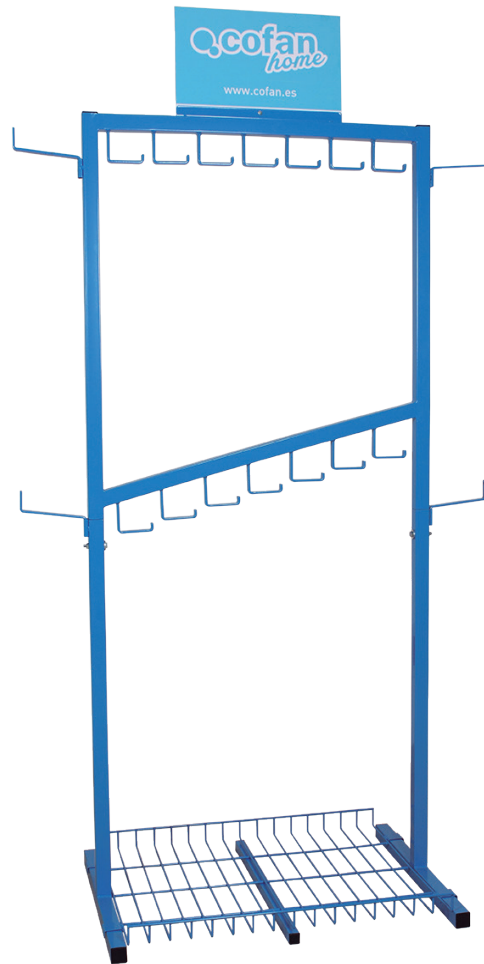

Se suministra sin paelleras.

COCINA / CUISINE / KITCHEN / CUCINA / COZINHA

Accesorios / Accessoires / Accessories / Accessori / Acessórios



Base de Polipropileno TNT tejido sin tejer y soporte de PVC estampado.
Rollo de 1,40 x 25 m de longitud. Made in Spain.

Base en Polypropylène TNT tissu non tissé et support en PVC imprimé.
Rouleau de 1,40 x 25 m de longueur. Made in Spain.

Polypropylene based, non-woven fabric and printed PVC coating.
Roll measures: 1,40 x 25 m long. Made in Spain.

Base in Polipropilene, tessuto non tessuto (TNT) e supporto in PVC impresso.
Rotola da 1,40 m x 25 m di lunghezza. Made in Spain.

Base de Polipropileno TNT não tecido e suporte de PVC estampado.
Rolo de 1,40 x 25 m de comprimento. Made in Spain.

Mod. Fiorentina



ROLLO SEMIHULE BÁSICO
ROULEAU BULGOMME BASIQUE
OILCLOTH ROLL BASIC
ROTOLO GOMMA BASE
ROLO PLÁSTICO BASICO

4100 4201:
€: 53,50 / IVA: 64,74

Mod. Dalby

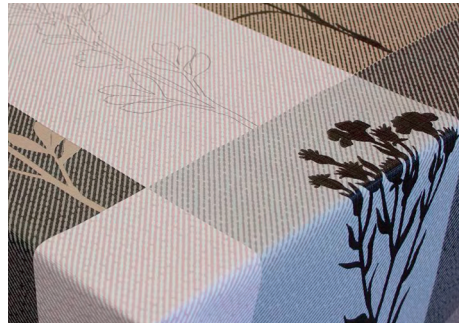

ROLLO SEMIHULE BÁSICO
ROULEAU BULGOMME BASIQUE
OILCLOTH ROLL BASIC
ROTOLO GOMMA BASE
ROLO PLÁSTICO BASICO

4100 4202:
€: 53,50 / IVA: 64,74

Mod. Retro

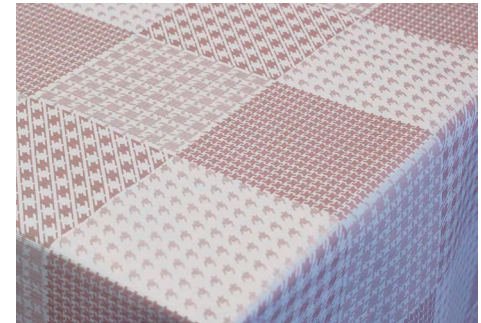

ROLLO SEMIHULE BÁSICO
ROULEAU BULGOMME BASIQUE
OILCLOTH ROLL BASIC
ROTOLO GOMMA BASE
ROLO PLÁSTICO BASICO

4100 4203:
€: 53,50 / IVA: 64,74



Antimanchas
Anti-tache
Stain resistant
Antimacchia
Antimancha

Mod. Garden



ROLLO SEMIHULE BÁSICO
ROULEAU BULGOMME BASIQUE
OILCLOTH ROLL BASIC
ROTOLO GOMMA BASE
ROLO PLÁSTICO BASICO

4100 4204:
€: 53,50 / IVA: 64,74

Mod. Heda



ROLLO SEMIHULE BÁSICO
ROULEAU BULGOMME BASIQUE
OILCLOTH ROLL BASIC
ROTOLO GOMMA BASE
ROLO PLÁSTICO BASICO

4100 4205:
€: 53,50 / IVA: 64,74

Mod. Capuccino



ROLLO SEMIHULE BÁSICO
ROULEAU BULGOMME BASIQUE
OILCLOTH ROLL BASIC
ROTOLO GOMMA BASE
ROLO PLÁSTICO BASICO

4100 4206:
€: 53,50 / IVA: 64,74

COCINA / CUISINE / KITCHEN / CUCINA / COZINHA

Accesorios / Accessoires / Accessories / Accessori / Acessórios



Base de Polipropileno TNT tejido sin tejer y soporte de PVC estampado.
Rollo de 1,40 x 25 m de longitud. Made in Spain.

Base en Polypropylène TNT tissu non tissé et support en PVC imprimé.
Rouleau de 1,40 x 25 m de longueur. Made in Spain.

Polypropylene based, non-woven fabric and printed PVC coating.
Roll measures: 1,40 x 25 m long. Made in Spain.

Base in Polipropilene, tessuto non tessuto (TNT) e supporto in PVC impresso.
Rotola da 1,40 m x 25 m di lunghezza. Made in Spain.

Base de Polipropileno TNT não tecido e suporte de PVC estampado.
Rolo de 1,40 x 25 m de comprimento. Made in Spain.

Mod. Vegan



ROLLO SEMIHULE BÁSICO
ROULEAU BULGOMME BASIQUE
OILCLOTH ROLL BASIC
ROTOLO GOMMA BASE
ROLO PLÁSTICO BASICO

4100 4207:

€: 53,50 / IVA: 64,74

Mod. Topes



ROLLO SEMIHULE BÁSICO
ROULEAU BULGOMME BASIQUE
OILCLOTH ROLL BASIC
ROTOLO GOMMA BASE
ROLO PLÁSTICO BASICO

4100 4208:

€: 53,50 / IVA: 64,74



Base de algodón sin tejer y soporte de PVC estampado.
Rollo de 1,40 x 25 m de longitud. Made in Spain.

Base en coton non tissée et support en PVC imprimé.
Rouleau de 1,40 x 25 m de longueur. Made in Spain.

Non-woven cotton base and printed PVC coating.
Roll measures: 1,40 x 25 m long. Made in Spain.

Base in cotone TNT e supporto in PVC impresso.
Rotola da 1,40 m x 25 m di lunghezza. Made in Spain.

Base de algodão, não tecido e suporte de PVC estampado.
Rolo de 1,40 x 25 m de comprimento. Made in Spain.



Antimanchas
Anti-tache
Stain resistant
Antimacchia
Antimancha

Mod. Atlantic



ROLLO SEMIHULE ALGODÓN
ROULEAU BULGOMME COTON
OILCLOTH ROLL COTTON
OILCLOTH ROLL COTTON
ROLO PLÁSTICO ALGODÃO

4100 4301:
€: 93,00 / IVA: 112,53

Mod. Vivaldi



ROLLO SEMIHULE ALGODÓN
ROULEAU BULGOMME COTON
OILCLOTH ROLL COTTON
OILCLOTH ROLL COTTON
ROLO PLÁSTICO ALGODÃO

4100 4302:
€: 93,00 / IVA: 112,53

Mod. Seattle



ROLLO SEMIHULE ALGODÓN
ROULEAU BULGOMME COTON
OILCLOTH ROLL COTTON
OILCLOTH ROLL COTTON
ROLO PLÁSTICO ALGODÃO

4100 4303:
€: 93,00 / IVA: 112,53

COCINA / CUISINE / KITCHEN / CUCINA / COZINHA

Accesorios / Accessoires / Accessories / Accessori / Acessórios



Base de algodón sin tejer y soporte de PVC estampado.
Rollo de 1,40 x 25 m de longitud. Made in Spain.

Base en coton non tissée et support en PVC imprimé.
Rouleau de 1.40 x 25 m de longueur. Made in Spain.

Non-woven cotton base and printed PVC coating.
Roll measures: 1,40 x 25 m long. Made in Spain.

Base in cotone TNT e supporto in PVC impresso.
Rotola da 1,40 m x 25 m di lunghezza. Made in Spain.

Base de algodão, não tecido e suporte de PVC estampado.
Rolo de 1,40 x 25 m de comprimento. Made in Spain.

Mod. Romantic Letters



ROLLO SEMIHULE ALGODÓN
ROULEAU BULGOMME COTON
OILCLOTH ROLL COTTON
OILCLOTH ROLL COTTON
ROLO PLÁSTICO ALGODÃO

4100 4304:

€: 93,00 / IVA: 112,53

Mod. Patchwork



ROLLO SEMIHULE ALGODÓN
ROULEAU BULGOMME COTON
OILCLOTH ROLL COTTON
OILCLOTH ROLL COTTON
ROLO PLÁSTICO ALGODÃO

4100 4305:

€: 93,00 / IVA: 112,53

Mod. Cuori



ROLLO SEMIHULE ALGODÓN
ROULEAU BULGOMME COTON
OILCLOTH ROLL COTTON
OILCLOTH ROLL COTTON
ROLO PLÁSTICO ALGODÃO

4100 4306:

€: 93,00 / IVA: 112,53



Antimanchas
Anti-tache
Stain resistant
Antimacchia
Antimancha

Mod. Cupcakes



ROLLO SEMIHULE ALGODÓN
ROULEAU BULGOMME COTON
OILCLOTH ROLL COTTON
OILCLOTH ROLL COTTON
ROLO PLÁSTICO ALGODÃO

4100 4307:
€: 93,00 / IVA: 112,53

Mod. Nueva Escocia

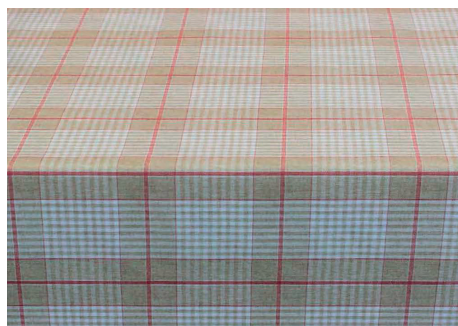

ROLLO SEMIHULE ALGODÓN
ROULEAU BULGOMME COTON
OILCLOTH ROLL COTTON
OILCLOTH ROLL COTTON
ROLO PLÁSTICO ALGODÃO

4100 4308:
€: 93,00 / IVA: 112,53

Mod. Lavanda

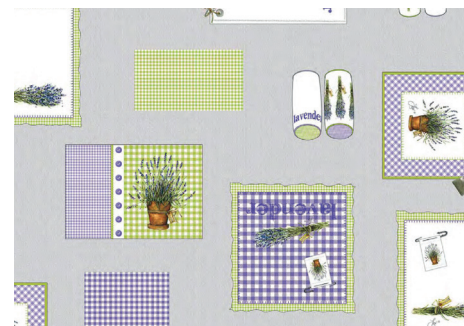

ROLLO SEMIHULE ALGODÓN
ROULEAU BULGOMME COTON
OILCLOTH ROLL COTTON
OILCLOTH ROLL COTTON
ROLO PLÁSTICO ALGODÃO

4100 4309:
€: 93,00 / IVA: 112,53

COCINA / CUISINE / KITCHEN / CUCINA / COZINHA

Accesorios / Accessoires / Accessories / Accessori / Acessórios



50% algodón y 50% poliéster. Estampado, tratamiento polímeros de resina acrílica más antimanchas. Rollo de 1,40 x 25 m de longitud. Made in Spain.

50% coton et 50% polyester. Impression, traitement polymères de résine acrylique et antitaches. Rouleau de 1.40 x 25 m de longueur. Made in Spain.

50% cotton and 50% polyester. Printed, acrylic resin polymer treatment and stain resistant. Roll measures: 1.40 x 25 m long. Made in Spain.

50% cotone e 50% poliestere. Impresso, trattamento con polimeri di resina acrilica antimacchia. Rotola da 1,40 m x 25 m di lunghezza. Made in Spain.

50% algodão e 50% poliéster. Estampado, Tratamento de polímeros de resina acrílica mais anti-manchas. Rolo de 1,40 x 25 m de comprimento. Made in Spain.

Mod. Royal Gris

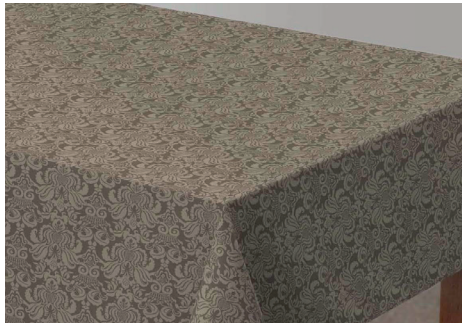

ROLLO HULE
ROULEAU BULGOMME
STAIN RESISTANT OIL CLOTH ROLL
ROTOLO GOMMA
ROLO PLÁSTICO

4100 4401:
€: 142,25 / IVA: 172,13

Mod. Royal Beige

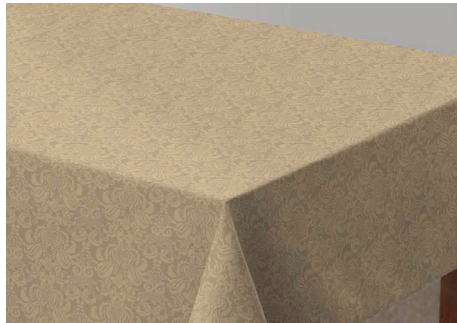

ROLLO HULE
ROULEAU BULGOMME
STAIN RESISTANT OIL CLOTH ROLL
ROTOLO GOMMA
ROLO PLÁSTICO

4100 4402:
€: 142,25 / IVA: 172,13

Mod. Miró



ROLLO HULE
ROULEAU BULGOMME
STAIN RESISTANT OIL CLOTH ROLL
ROTOLO GOMMA
ROLO PLÁSTICO

4100 4403:
€: 142,25 / IVA: 172,13



Antimanchas
Anti-tache
Stain resistant
Antimacchia
Antimancha

Mod. Fiorella



ROLLO HULE
ROULEAU BULGOMME
STAIN RESISTANT OIL CLOTH ROLL
ROTOLO GOMMA
ROLO PLÁSTICO

4100 4404:
€: 142,25 / IVA: 172,13

Mod. Tamariz



ROLLO HULE
ROULEAU BULGOMME
STAIN RESISTANT OIL CLOTH ROLL
ROTOLO GOMMA
ROLO PLÁSTICO

4100 4405:
€: 142,25 / IVA: 172,13

Mod. Frutal



ROLLO HULE
ROULEAU BULGOMME
STAIN RESISTANT OIL CLOTH ROLL
ROTOLO GOMMA
ROLO PLÁSTICO

4100 4406:
€: 142,25 / IVA: 172,13

● ALMACENAJE / RANGEMENT STORAGE / CONTENITORI ARRUMAÇÃO

●
168

Botellers

Rangement bouteilles

Bottle racks

Portabottiglie

Garrafeiras

●
170

Cajoneras

Meuble à tiroirs

Storage drawers

Contenitori

Bloco de gavetas

●
172

Accesorios

Accessoires

Accessories

Accessori

Acessórios

●
174

Felpudos

Paillassons

Doormats

Zerbini

Tapetes



ALMACENAJE / RANGEMENT / STORAGE / CONTENITORI / ARRUMAÇÃO

Botelleros / Rangement bouteilles / Bottle racks / Portabottiglie / Garrafeiras



Botelleros de plástico resistentes y apilables en color simulación "Rústico" con capacidad para 4 ó 6 botellas. Posibilidad de tapa superior de complemento, ideal para convertirlos en estantes ornamentales o baldas de almacenamiento.

Support rangement bouteilles en plastique, résistants et empilables couleur imitation 'rustique', capacité 4 ou 6 bouteilles. Possibilité de revêtement supérieur en complément, idéal pour les transformer en étagères d'ornement ou en espace de rangement.

Stakable plastic bottle racks, simulating a "rustic" colour and capacity to store 4 or 6 bottles. Possibility to add a supplementary lid, ideal for turning them into decorative or storage shelves.

Portabottiglie di plastica resistente e impalabili. Di colore "rustico" con capacità per 4 o 6 bottiglie. Possibilità di copertura superiore, ideali per essere convertiti in ornamenti o scaffali.

Garrafeiras de plástico resistentes e empilháveis em cor simulando "Ruístico" com uma capacidade para 4 ou 6 garrafas. Pode ter uma tampa superior de complemento, ideal para converte-los em estantes ou prateleiras de armazenamento.



TAPA BOTELLERO PLASTIC RÚSTICO 4 BOTELLAS
COUVERCLE RANGE BOUTEILLES PLASTIQUE RUSTIQUE 4 BOUTEILLES
COVER OF RUSTIC PLASTIC WINE RACK, 4 BOTTLES
COPERTURA PER PORTABOTTIGLIE IN PLASTICA, 4 BOTTIGLIE
TAMPA EXPOSITOR RÚSTICO 4 GARRAFAS PLÁSTICO

4160 0203: 410 x 240 x 240 mm

€: 3,62 / IVA: 4,38

1/6



BOTELLERO PLASTIC RÚSTICO 4 BOTELLAS
RANGE BOUTEILLES PLASTIQUE RUSTIQUE 4 BOUTEILLES
RUSTIC PLASTIC WINE RACK, 4 BOTTLES
PORTABOTTIGLIE RUSTICO IN PLASTICA, 4 BOTTIGLIE
EXPOSITOR RÚSTICO 4 GARRAFAS PLÁSTICO

4160 0201: 410 x 240 x 240 mm

€: 4,03 / IVA: 4,87

2/12

TAPA BOTELLERO PLASTIC RÚSTICO 6 BOTELLAS
COUVERCLE RANGE BOUTEILLES PLASTIQUE RUSTIQUE 6 BOUTEILLES
COVER OF RUSTIC PLASTIC WINE RACK, 6 BOTTLES
COPERTURA PER PORTABOTTIGLIE IN PLASTICA, 6 BOTTIGLIE
TAMPA EXPOSITOR RÚSTICO 6 GARRAFAS PLÁSTICO

4160 0204: 630 x 235 x 75 mm

€: 3,62 / IVA: 4,38

1/6



BOTELLERO PLASTIC RÚSTICO 6 BOTELLAS
RANGE BOUTEILLES PLASTIQUE RUSTIQUE 6 BOUTEILLES
RUSTIC PLASTIC WINE RACK, 6 BOTTLES
PORTABOTTIGLIE RUSTICO IN PLASTICA, 6 BOTTIGLIE
EXPOSITOR RÚSTICO 6 GARRAFAS PLÁSTICO

4160 0202: 630 x 235 x 75 mm

€: 5,21 / IVA: 6,30

2/12

ALMACENAJE / RANGEMENT / STORAGE / CONTENITORI / ARRUMAÇÃO

Cajoneras / Meuble à tiroirs / Storage drawers / Contenitori / Bloco de gavetas

Para poner orden en tu casa con prácticos baúles de plástico transparente, organizando bajocamas, zapateros, manteros o prácticos pufs con almacenaje, preservando los contenidos de olores, humedades y suciedades molestas.

Voici la solution pour ranger votre maison avec ces box en plastique transparent, pour ranger en dessous du lit, chaussures, bibelots divers, en préservant des parfums, de l'humidités et de la poussière.

To organise your house with useful storage trunks made of transparent plastic, sorting blankets under bed, shoes, pouffes with storage and protecting all contents from smells, humidity and dirt.

Adatti per ordinare la casa. Pratici contenitori in plastica trasparente da riporre sotto i letti, per conservare scarpe e oggetti di varie dimensioni, preservando il contenuto da odori, umidità e sporcizia.

Para pôr em ordem a tua casa com prácticos baús de plástico transparente, para organizar debaixo das camas, sapatos, cobertores ou pufes prácticos com armazenamento, preservando o conteúdo de cheiros, humidade e sujidade.



CAJONERA RUEDAS 3 Y 5 CAJONES
COLONNE SUR ROULETTES 3 ET 5 TIRROIRS
PLASTIC STORAGE TOWER WITH WHEELS, 3 AND 5 DRAWERS
CONTENITORE CON RUOTE, 3 E 5 CASSETTI
ESTANTE C/ RODAS 3 E 5 CAIXAS

4160 1141: 270 x 360 x 630 mm

€: 18,27 / IVA: 22,11



4160 1142: 270 x 360 x 820 mm

€: 27,72 / IVA: 33,54



BAÚL PLASTIC
BOITE DE RANGEMENT PLASTIQUE
PLASTIC STORAGE TRUNKS
CONTENITORE IN PLASTICA
BAÚ DE PLÁSTICO

4160 1151: 4 l · 290 x 190 x 130 mm

€: 2,41 / IVA: 2,92



4160 1152: 9 l · 369 x 245 x 166 mm

€: 4,22 / IVA: 5,11



4160 1153: 13 l · 400 x 270 x 190 mm

€: 4,80 / IVA: 5,81



4160 1154: 17 l · 405 x 320 x 230 mm

€: 4,70 / IVA: 5,69



4160 1155: 30 l · 487 x 390 x 264 mm

€: 7,52 / IVA: 9,10



ALMACENAJE / RANGEMENT / STORAGE / CONTENITORI / ARRUMAÇÃO

Accesorios / Accessoires / Accessories / Accessori / Acessórios



Artículos para cuidar la ropa en varias estancias del hogar; perchas y colgadores para puertas y rincones; tendederos extensibles para el secado de la ropa en exteriores, y perchas de color blanco para guardar de las prendas, tanto delicadas como pesadas, teniendo organizados todos los roperos.

Articles pour ranger les vêtements dans plusieurs lieux de la maison: cintres et patères pour portes et recoins; étendoirs extensibles pour séchages des vêtements à l'extérieur et cintres blancs pour pendre des articles fragiles ou lourds, permettant d'organiser toutes les penderies.

Cofanhome propose several items to take care of your clothes in several rooms at home: hangers and coat hook rails for doors and corners; extendable airers to dry clothes outdoor and white hangers to keep delicate garments as well as heavy ones, always having all wardrobes well organised.

Articoli per appendere i vestiti nelle varie stanze della casa: grucce e appendini per porte; stenditoi estensibili per asciugare i panni all'aperto e appendiabiti di colore bianco per ordinari tutti gli armadi.

Artigos para cuidar da roupa em várias divisões da casa: cabides e ganchos para as portas e cantos; extensível para exteriores para secagem da roupa e cabides brancos para o cuidado da roupa delicada e pesada, para ter organizado todos os armários.



PACK DE 3 PERCHAS PLASTIC BLANCO
 PACK DE 3 CINTRES PLASTIQUE BLANC
 3 WHITE PLASTIC CLOTHES HANGERS
 CONFEZIONE DI 3 GRUCCE BIANCHE, IN PLASTICA
 PACK 3 GANCHOS PLÁSTICO BRANCOS

4160 0225:
 €: 2,70 / IVA: 3,27

 1/24



TENDEDERO EXTENSIBLE 3 CUERDAS
 FILT A LINGE EXTENSIBLE 3 CORDES
 EXTENDIBLE CLOTHES DRYER, 3 CORDS
 STENDIBIANCHERIA ESTENSIBILE A 3 CORDE
 ESTENDEDOR EXTENSIVEL ROUPAR 3 CORDAS

4160 0243: 5 m
 €: 11,81 / IVA: 14,30

 1/6

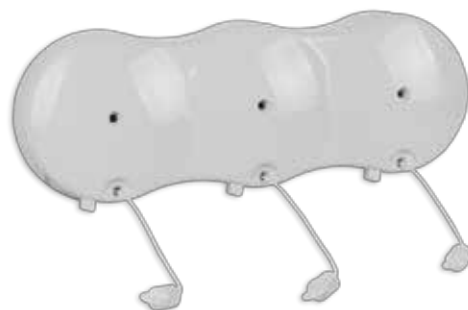

PERCHA COLGADOR PARA PUERTAS
 PATERE POUR PORTES
 CLOTHES HOLDER FOR DOORS
 ATTACCAPANNI PER PORTA
 SUPORTE DE ROUPA P/ PORTAS

4160 0261:
 €: 5,02 / IVA: 6,07

 1/8

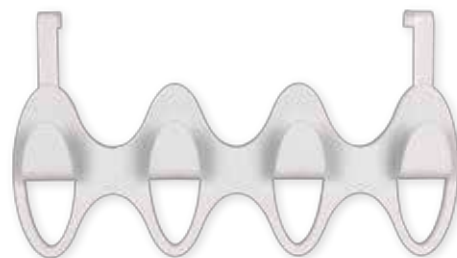

ALMACENAJE / RANGEMENT / STORAGE / CONTENITORI / ARRUMAÇÃO

Felpudos / Paillassons / Doormats / Zerbini / Tapetes



Felpudos de caucho y felpudos de caucho con moqueta en color negro. Ofrecen una cálida bienvenida a tu hogar y son ideales para eliminar restos de los zapatos y mantener la mejor carta de presentación en las entradas.

Paillassons en caoutchouc et paillassons en caoutchouc et moquette noire. Ils offrent un accueil chaleureux dans votre maison et leur revêtement permet d'éliminer les débris des chaussures et ainsi offrir une jolie présentation à l'entrée de votre maison.

Black rubber doormats and rubber-carpet doormats offer a warm welcome to your home and are ideal for removing debris from shoes and for keeping the best appearance when coming into a house.

Zerbini in plastica e gomma con moquette di colore nero. Questi prodotti offrono un caldo benvenuto alla vostra casa e sono ideali per la rimozione di detriti dalle scarpe mantenere la miglior presentazione possibile degli ingressi.

Tapetes de borracha e tapetes de borracha com carpete na cor preta. Eles oferecem uma recepção calorosa à sua casa e são ideais para remover os restos dos sapatos e manter a melhor apresentação nas entradas.



FELPUDO CAUCHO 100%
PAILLASON 100% CAOUTCHOUC
100% RUBBER DOORMAT
ZERBINO 100% IN GOMMA
TAPETE DE ENTRADA BASE EM BORRACHA 100%

4160 0121: 540 x 340 mm

€: 5,43 / IVA: 6,56

 1/10

4160 0122: 690 x 440 mm

€: 6,37 / IVA: 7,70

 1/10

FELPUDO CAUCHO/MOQUETA
PAILLASON CAOUTCHOUC/MOQUETTE
RUBBER/CARPET DOORMAT
ZERBINO IN GOMMA / MOQUETTE
TAPETE DE ENTRADA BASE EM BORRACHA/CARPETE

4160 0125: 540 x 340 mm

€: 7,00 / IVA: 8,47

 1/10

4160 0126: 690 x 440 mm

€: 10,68 / IVA: 12,92

 1/10

FELPUDO MEDIA LUNA CAUCHO/MOQUETA
PAILLASON MEDIA LUNA CAUCHO/MOQUETA
HALF-MOON RUBBER/CARPET DOORMAT
ZERBINO A MEZZALUNA IN GOMMA/MOQUETTE
TAPETE MEIA LUA EM BORRACHA/CARPETE

4160 0127: 650 x 400 mm

€: 7,50 / IVA: 9,07

 1/10



ALMACENAJE / RANGEMENT / STORAGE / CONTENITORI / ARRUMAÇÃO

Felpudos / Paillassons / Doormats / Zerbini / Tapetes

Felpudos para interior de polipropileno decorados en varios colores y felpudos de Coco pintados y floqueados que siempre son clásicos en la decoración y la limpieza del hogar.

Paillassons intérieur en polypropylène décorés en plusieurs coloris et paillassons coco peints et floqués, classiques pour la décoration et la propreté de la maison.

Polypropylene interior doormats decorated in several colours and painted or fringed coil doormats that are always typical in decoration and home cleaning.

Zerbini per interni in polipropilene decorati in vari colori e zerbini in cocco verniciati e floccati, classici nella decorazione e per la pulizia della casa.

Tapetes para interior de polipropileno decorados em várias cores e tapetes de Côco pintadas e floqueados que sempre serão um clássico na decoração e limpeza doméstica.



FELPUDO INTERIOR POLIPROPILENO
PAILLASSON INTÉRIEUR POLYPROPYLENE
DOORMAT POLYPROPYLENE INTERIOR
ZERBINO DA INTERNO IN POLIPROPILENE
TAPETE INTERIOR POLIPROPILENO



AZUL
BLEU
BLUE
BLU
AZUL

4160 0131: 400 x 600 mm
€: 6,20 / IVA: 7,50

1/10



MARRÓN
MARRON
BROWN
MARRONE
CASTANHO

4160 0132: 400 x 600 mm
€: 6,20 / IVA: 7,50

1/10



NEGRO/GRIS
NOIR/GRIS
BLACK/GREY
NERO/GRIGIO
PRETO/CINZENTO

4160 0133: 400 x 600 mm
€: 6,20 / IVA: 7,50

1/10



ROJO
ROUGE
RED
ROSSO
VERMELHO

4160 0134: 400 x 600 mm
€: 6,20 / IVA: 7,50

1/10

ALMACENAJE / RANGEMENT / STORAGE / CONTENITORI / ARRUMAÇÃO

Felpudos / Paillassons / Doormats / Zerbini / Tapetes

FELPUDO INTERIOR COCO PINTADO
PAILLASSON INTÉRIEUR COCO PEINT
DOORMAT PAINTED COIR INTERIOR
ZERBINO DA INTERNO IN COCCO VERNICIATO
TAPETE INTERIOR CÔCO PINTADO



OVEJA HOLA
BREBIS HOLA
HELLO SHEEP
HOLA PECORA
OVELHA HOLA

4160 0141: 400 x 600 mm
€: 10,20 / IVA: 12,34

1/10



HOLA IDIOMAS
BONJOUR LANGAGES
HELLO LANGUAGES
HOLA LINGUE
HOLA IDIOMAS

4160 0142: 400 x 600 mm
€: 10,20 / IVA: 12,34

1/10



PERRO HOLA
CHIEN HOLA
HELLO DOG
HOLA CANE
CÃO HOLA

4160 0143: 400 x 600 mm
€: 10,20 / IVA: 12,34

1/10



GATO HOLA
CHAT HOLA
HELLO CAT
HOLA GATTO
GATO HOLA

4160 0144: 400 x 600 mm
€: 10,20 / IVA: 12,34

1/10

FELPUDO INTERIOR COCO FLOQUEADO
 PAILLASSON INTÉRIEUR COCO FLOQUE
 DOORMAT FRINGED COIR INTERIOR
 ZERBINO DA INTERNO IN COCCO FLOCCATO
 TAPETE INTERIOR CÔCO FLOQUEADO

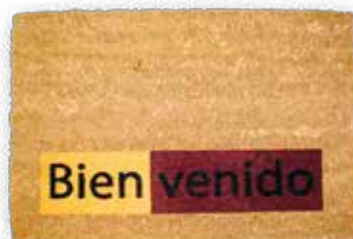

PERRO HOLA
 CHIEN HOLA
 HELLO DOG
 HOLA CANE
 CÃO HOLA

4160 0151: 400 x 600 mm
 €: 10,93 / IVA: 13,23

1/10

BIENVENIDO
 BIENVENUE
 WELCOME
 BENVENUTO
 BIENVENIDO

4160 0152: 400 x 600 mm
 €: 10,93 / IVA: 13,23

1/10

GATO HOLA
 CHAT HOLA
 HELLO CAT
 HOLA GATTO
 GATO HOLA

4160 0153: 400 x 600 mm
 €: 10,93 / IVA: 13,23

1/10

FLORES
 FLEURS
 FLOWERS
 FIORI
 FLORES

4160 0154: 400 x 600 mm
 €: 10,93 / IVA: 13,23

1/10

CALEFACCIÓN / CHAUFFAGE HEATING / RISCALDAMENTO CALEFAÇÃO

182

Estufas

Fourneaux

Burning stoves

Stufe

Estufas

188

Accesorios

Accessoires

Accessories

Accessori

Acessórios



CALEFACCIÓN / CHAUFFAGE / HEATING / RISCALDAMENTO / CALEFAÇÃO

Estufas / Fourneaux / Burning stoves / Stufe / Estufas



Mod. Kanaga

La estufa "Modelo Kanaga" con interior de ladrillo refractario, incorpora un cajón para la extracción de ceniza. Ideal para combustible de leña. Cristal vitrocerámico. Pintura anticorrosiva de alta resistencia en todo el cuerpo de acero. Salida de humos superior de 15 cm y cuerpo central en acero de 4 mm.

Le poêle "Modèle Kanaga", intérieur en brique réfractaire, comprend un tiroir pour l'extraction des cendres. Idéal pour buches de chauffage. Vitre vitrocéramique. Peinture anti calorique haute résistance sur toute la carcasse en acier. Sortie de fumées supérieure à 15 cm et corps central en acier de 4 mm.

The wood burning stove, "Kanaga Model", has a firebrick interior and a drawer for extracting ashes. Suitable for charcoal. Vitro-ceramic glass. High heat-resistant paint in all its stainless steel body. 15 cm-long top flue outlet and 4 mm-thick central steel body.

La stufa "Modelo Kanaga" con pareti interne in mattone refrattario, incorpora un cassetto per la rimozione della cenere. Ideale per legna. Vetrocera mica. Vernice anticorrosione ad alta resistenza su tutta la superficie in acciaio. Fuoriuscita superiore dei fumi da 15 cm e corpo centrale in acciaio da 4 mm.

A salamandra "Modelo Kanaga" com interior de tijolo refratário incorpora uma gaveta para remoção de cinzas. Ideal para combustível de lenha. Vidro vitrocerâmico de alta resistência em todo o corpo de aço. Saída superior para fumos de 15 cm e corpo central em aço de 4 mm.

    
15cm 15,5kw 60% 90-110m² 100kg

ESTUFA ACERO DE LEÑA
POELE A BOIS EN ACIER
STEEL WOOD-BURNING STOVE
STUFA A LEGNA IN ACCIAIO
SALAMANDRA AÇO DE LENHA

4300 2035:
€: 596,70 / IVA: 722,00

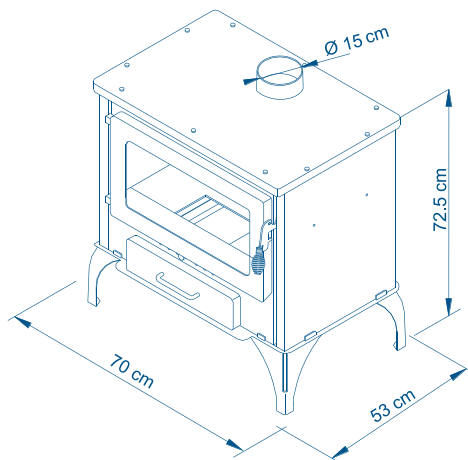

CALEFACCIÓN / CHAUFFAGE / HEATING / RISCALDAMENTO / CALEFAÇÃO

Estufas / Fourneaux / Burning stoves / Stufe / Estufas



Mod. Irazu

La estufa "Modelo Irazu" especial para rincones con interior de ladrillo refractario, incorpora un horno con tapa frontal, cajón para la extracción de ceniza y leñero en el frontal. Ideal para combustible de leña. Cristal vitrocerámico. Pintura anticorrosiva de alta resistencia en cuerpo de acero. Salida de humos superior de 15 cm, cuerpo en acero de 4 mm y cuerpo central en acero de 4 mm.

Le Poêle Modèle Irazu "spécial pour les angles avec intérieur en brique réfractaire, comprend un foyer avec ouverture frontale, tiroir pour l'extraction de cendre et tiroir à bûche frontal. Idéal pour bûches de chauffage. Vitre vitrocéramique. Peinture anti calorique haute résistance sur la carcasse en acier. Sortie de fumées supérieure à 15 cm corps en acier de 4 mm et corps central en acier de 4 mm.

The wood-burning stove "Irazu Model" is special for corners with firebrick interior. It has in its front side an oven with lateral-opening door, a drawer for extracting ashes and another one for wood. High heat-resistant paint in all its stainless steel body. 15 cm-long top flue outlet, 4 mm-thick steel body and 4 mm-thick central steel body.

La stufa angolare "Modelo Irazu" è progettata per adattarsi ad ogni ambiente della casa. Pareti interne in mattone refrattario. Incorpora un forno con apertura frontale, un cassetto per la rimozione della cenere e un vano portalegna. Ideale per legna. Vetroceramica. Vernice anticorrosione ad alta resistenza sulla superficie in acciaio. Fuoriuscita superiore dei fumi da 15 cm, corpo in acciaio da 4 mm e corpo centrale da 4 mm.

A salamandra "Modelo Irazu" especial para cantos con interior de tijolo refratário, incorpora um forno com tampa frontal, gaveta para a extração da cinza e depósito de lenha na parte dianteira. Ideal para o combustível de lenha. Vidro vitrocerâmico. Pintura anticorrosiva de alta resistência no corpo de aço. Respiradouro superior de 15 cm corpo em aço de 4mm, e corpo central em aço 4 mm.

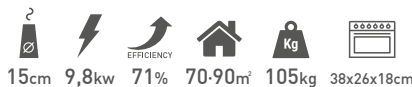

15cm 9,8kw 71% 70-90m² 105kg 38x26x18cm

ESTUFA RINCÓN ACERO LEÑA
POELE A BOIS D'ANGLE EN ACIER
STEEL WOOD-BURNING STOVE FOR CORNER
STUFA A LEGNA AD ANGOLO, IN ACCIAIO
SALAMANDRA DE CANTO AÇO LENHA

4300 2036:

€: 673,30 / IVA: 814,70

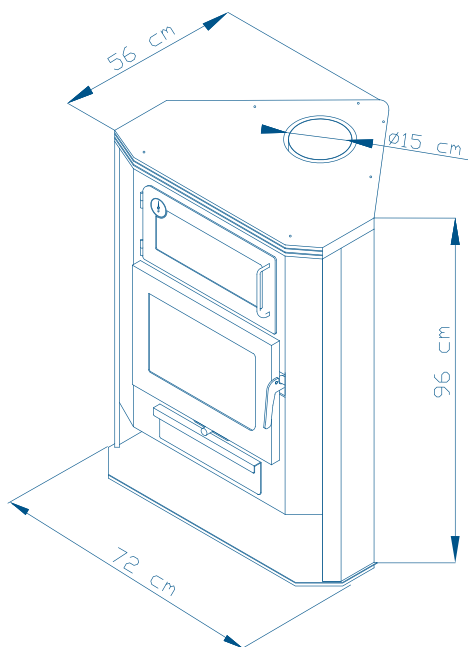

CALEFACCIÓN / CHAUFFAGE / HEATING / RISCALDAMENTO / CALEFAÇÃO

Estufas / Fourneaux / Burning stoves / Stufe / Estufas



Mod. Madeira

La estufa "Modelo Madeira" con interior de ladrillo refractario, incorpora un horno con tapa frontal, cajón para la extracción de ceniza y leñero en el frontal. Ideal para combustible de leña. Cristal vitrocerámico. Pintura anticorrosiva de alta resistencia en cuerpo de acero. Salida de humos superior de 15 cm, cuerpo en acero de 4 mm y cuerpo central en acero de 4 mm.

Le poêle "Modèle Madeira" , intérieur en brique réfractaire, comprend un foyer avec fermeture frontale, tiroir pour l'extraction de cendre et tiroir à bûche frontal. Idéal pour bûches de chauffage. Vitre vitrocéramique. Peinture anti calorique haute résistance sur la carcasse en acier. Sortie de fumées supérieure à 15 cm, corps en acier de 4 mm et corps central en acier de 4 mm.

The wood burning stove, "Madeira Model", with firebrick interior, has in its front side an oven with lateral-opening door, a drawer for extracting ashes and another one for wood. Suitable for charcoal. Vitro-ceramic glass. High heat-resistant paint in all its stainless steel body. 15 cm-long top flue outlet, 4 mm-thick steel body and 4 mm-thick central steel body.

La stufa "Modello Madeira" con pareti interne in mattone refrattario, incorpora un forno con apertura frontale, un cassetto per la rimozione della cenere e un vano portalegna. Ideale per legna. Vetroceramica. Vernice anticorrosione ad alta resistenza sulla superficie in acciaio. Fuoriuscita superiore dei fumi da 15 cm, corpo in acciaio da 4 mm e corpo centrale da 4 mm.

A salamandra "Modelo Madeira" com interior de tijolo refratário incorpora um forno com tampa frontal, gaveta para remoção de cinzas e depósito de lenha na frente. Ideal para combustível de lenha. Vidro vitrocerâmico. Pintura anticorrosiva de alta resistência em todo o corpo de aço. Respiradouro superior de 15 cm corpo em aço de 4mm, e corpo central em aço 4 mm.

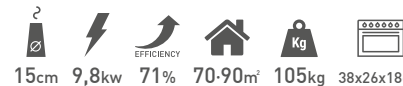

15cm 9,8kw 71% 70-90m² 105kg 38x26x18cm

ESTUFA HORNO ACERO LEÑA
POELE A BOIS FOYER EN ACIER
STEEL WOOD-BURNING STOVE OVEN
STUFA A LEGNA IN ACCIAIO CON FORNO
SALAMANDRA FORNO AÇO LENHA

4300 2037:

€: 673,30 / IVA: 814,70

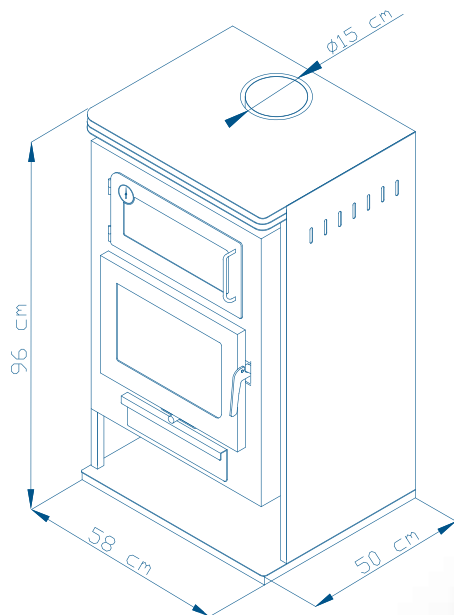

CALEFACCIÓN / CHAUFFAGE / HEATING / RISCALDAMENTO / CALEFAÇÃO

Accesorios / Accessoires / Accessories / Accessori / Acessórios

TUBO PARA CHIMENEA
TUBE POUR CHEMINÉE
CHIMNEY PIPE
TUBO PER CAMINO
TUBO PARA CHAMINÉ

4300 2041: Ø150mm x 1m
€: 16,12 / IVA: 19,51

 1



TUBO PARA CHIMENEA CON REGISTRO
TUBE POUR CHEMINÉE AVEC CLÉ
CHIMNEY PIPE WITH DAMPER
TUBO PER CAMINO CON REGISTRO
TUBO PARA CHAMINÉ COM CHAVE

4300 2042: Ø150mm x 1m
€: 24,41 / IVA: 29,54

 1



CODO 45° TUBO ESTUFA
COUDE 45° TUBE POËLE
45° ELBOW BURNING STOVE PIPE
TUBO A 45° PER STUFA
TUBO DE COTOVELO 45° SALAMANDRA

4300 2043: Ø150mm
€: 14,92 / IVA: 18,06

📦 1



"T" PARA TUBO ESTUFA
"T" POUR TUBE POËLE
TEE FOR BURNING STOVE PIPE
TUBO A "T" PER STUFA
"T" PARA TUBO SALAMANDRA

4300 2045: Ø150mm
€: 21,45 / IVA: 25,95

📦 1



SOMBRERO PARA TUBO DE ESTUFA
CHAPEAU POUR TUBE DE POËLE
RAIN CAP FOR BURNING STOVE PIPE
TERMINALE PARAPIOGGIA PER STUFA
CHAPÉU PARA TUDO DE SALAMANDRA

4300 2046: Ø150mm
€: 24,75 / IVA: 29,95

📦 1





Condiciones Generales de Venta

TRANSPORTE – RIESGOS

La mercancía viaja a cuenta y riesgo del comprador, cual sea el modo de expedición; por consiguiente, todo conflicto relativo a este transporte ha de ser solucionado entre el comprador y el transportista.

DEVOLUCIONES

Una vez recepcionada la mercancía, no se admitirá su devolución. A título excepcional y por causas justificadas se admitirán las devoluciones, canjeándose los productos por otros, siendo los gastos que esta devolución acarree por parte del comprador.

CLÁUSULA DE RESERVA DE PROPIEDAD

De convenio expreso, conservamos la presente mercancía hasta el pago íntegro de su precio. Talones, efectos y "sumisión de credenciales" sólo serán considerados como pagos a partir del cobro efectivo acerca del comprador.

En caso de no cobrar el precio, el contrato será anulado con pleno derecho desde nuestra solicitud por simple carta certificada dirigida al comprador.

La restitución de mercancías impagadas queda debida por el comprador que falla, a sus gastos y riesgos desde nuestra intimación por carta certificada.

GARANTÍA

De convenio expreso, nuestra responsabilidad no podrá ser comprometida en el caso en que un estudio técnico se revelara insuficiente y en el cual apareciera que dicho material es impropio al uso al que el comprador lo destinaba.

La garantía se aplicará para la venta de un material a un cliente con la reserva que éste respete los consejos e instrucciones de uso y mantenimiento del material dados en la documentación adjunta que incorpora el elemento vendido o en su defecto las instrucciones dadas por el personal de Cofan. El plazo de garantía es de 6 meses para todos los materiales nuevos.

Esta garantía sólo concierne estos mismos materiales sin considerar otros perjuicios que podrían ocasionar.

RECLAMACIONES

De convenio expreso, los Tribunales competentes serán los de nuestra elección para contestar de toda dificultad que pueda nacer de la ejecución o interpretación de los presentes convenios, aunque sea en el caso de pluralidad de demandados (defensores) o de solicitud de garantía.

Conditions De Vente

TRANSPORTS – RISQUES

Les marchandises voyagent aux risques et périls de l'acheteur quel que soit le mode d'expédition; par conséquent, toute contestation relative à ce transport doit être réglée directement entre l'acheteur et le transporteur.

RETOUR DE MARCHANDISE

Une fois la marchandise réceptionnée, aucun retour ne sera autorisé. A titre exceptionnel et pour des causes justifiées, nous pourrions autoriser certains retours de marchandise, et le remboursement sera effectué par un échange de produits. Les frais occasionnés par ces retours seront à la charge de l'acheteur.

CLAUSE DE RESERVE DE PROPRIETE

Il est expressément convenu que nous conservons la propriété des marchandises jusqu'au paiement intégral de leur prix. Les chèques, lettres de change et cession de créances, ne sont considérés comme paiements qu'à la date de leur encaissement effectif auprès de l'acheteur.

En cas de non paiement du prix, le contrat sera annulé de plein droit à notre demande par simple lettre recommandée adressée à l'acheteur.

La restitution des marchandises impayées sera due par l'acheteur défaillant à ses frais et risques sur notre mise en demeure par lettre recommandée.

GARANTIE

De convention expresse, notre responsabilité ne pourra être engagée dans le cas où une étude technique se révélerait insuffisante et où il apparaîtrait que le-dit matériel est impropre à l'usage auquel l'acheteur le destinait.

La garantie s'appliquera lors de la vente d'un matériel au consommateur sous réserve que celui-ci respecte les conseils et instructions d'emploi et d'entretien du matériel donnés par le vendeur lors de la vente. Durée de garantie de six mois pour tous les matériels réparés et neufs.

Cette garantie concerne uniquement ces mêmes matériels et ne tient pas compte des préjudices qu'ils pourraient occasionner.

RECLAMATIONS

De convention expresse, les Tribunaux compétents seront ceux de notre choix afin de répondre à toute difficulté qui pourrait naître dans l'exécution ou dans l'interprétation des présentes conventions, même dans le cas de pluralité de demandeurs (défenseurs) ou de sollicitation de garantie.

Conditions Of Sale

RISKS OF TRANSPORT

The goods travel at the customer's risks, whatever the way of expedition may be, as a consequence, all contestings are to be resolved between the buyer and the forwarding agent.

RETURNS

Once the goods are received, their return will not be admitted. As an exceptional matter and righteous causes the returns will be admitted, changing the products by others, the expenses will be taken on behalf of the buyer.

CLAUSE OF PROPERTY RESERVATION

It is expressly agreed we retain the property of the goods till the entire payment of its price. Cheques, bills, would not be considered as payments till the effective encashment.

In case of insolvency, we would cancel the contract through registered letter. The restitution of non-paid goods is due by the buyer at his own risks and costs upon our formal notice (registered letter).

WARRANTY

We expressly agree our responsibility would not be committed in case of technical tests on goods would reveal insufficient and where it would appear the material is unfit to the buyer destinate use.

The legal warranty will apply under the reservation the customer has respected the advices, use and maintenance instructions given by the seller in the attached documents incorporated in the products sold or in the instructions given by Cofan staff.

The warranty period is six months for all new products. The warranty only concerns these very same products and does not apply to other damages it could cause.

CONTESTINGS

It is expressly agreed we will choose the competent tribunal in order to answer to eventual difficulties and misinterpretations from the execution of these agreements, even in case of plurality of defendants or callings in warranty.

Condizioni Generali di Vendita

TRASPORTI - RISCHIO

La merce viaggia a carico e rischio del compratore, qualunque sia il mezzo di spedizione; conseguentemente, ogni diatriba relativa al trasporto deve essere risolta fra compratore e trasportatore

RESI MERCE

"Una volta ricevuta la merce non sarà ammesso alcun reso. A titolo eccezionale e per cause giustificate saranno ammessi resi, in forma di sostituzione con altro prodotto. I costi di tale operazione sono a carico del compratore".

CLAUSOLA DI RISERVA DI PROPRIETÀ

"E" espressamente convenuto che manteniamo la proprietà della merce fino all'integrale saldo del suo prezzo. Titoli, assegni, cambiali o altri effetti saranno considerati validi ai fini del pagamento solo ad effettivo incasso.

In caso di mancato pagamento, il contratto di vendita si intende annullato con nostro pieno diritto, a nostra semplice richiesta a mezzo raccomandata inviata al compratore.

La restituzione della merce non pagata è a carico del compratore, a suo rischio e pericolo, a seguito di nostra intimazione alla restituzione."

GARANZIA

"Si conviene che non potrà esserci addebitata alcuna responsabilità nel caso venga verificato un uso improprio del materiale, diverso da quello per il quale lo stesso era destinato.

La garanzia si applica ad ogni contratto di vendita, a condizione che il compratore rispetti i consigli d'uso e le istruzioni di uso e manutenzione riportati da specifico libretto di istruzioni o, in assenza, vengano seguite le istruzioni impartite dal personale Cofan. Il termine di garanzia si intende pari a 6 mesi per ogni particolare nuovo.

La garanzia copre esclusivamente il materiale acquistato ed in nessun caso potrà essere estesa ad eventuali danni conseguenti all'uso del prodotto."

CONTESTAZIONI

Di comune accordo, si conviene che qualora fosse necessario un arbitrio per cause di garanzia o per la soluzioni di problematiche legate alla esecuzione o all'interpretazione delle presenti indicazioni, il tribunale competente sarà da noi stessi indicato, anche in caso di cause che coinvolgano più ricorrenti

Condições De Venda

CONDIÇÕES DE VENDA

A mercadoria viaja por conta e risco de o comprador, qualquer que seja o modo de entrega, portanto, qualquer litígio relacionado com esse transporte deve ser resolvido entre o comprador e o transportador.

DEVOLUÇÕES

Após a recepção das mercadorias, não será admitida a sua devolução. Em circunstâncias excepcionais e com causas justificadas serão admitidas as devoluções, trocando os produtos por outros, sendo os custos que impliquem esta devolução, por parte do comprador

CLÁUSULA DE RESERVA DE PROPRIEDADE

Fica expressamente acordado que nós manteremos a propriedade da mercadoria até todo o pagamento do seu preço. Cheques, notas, poderão não ser considerados como pagamentos até a cobrança efetiva.

Em caso de insolvência, nós poderemos cancelar o contrato por meio de carta registrada. A restituição da mercadoria não paga é devido pelo o comprador em seus próprios riscos e custos em nossa notificação formal (carta registrada).

GARANTIA

Concordamos expressamente que a nossa responsabilidade não será comprometida em caso de testes técnicos revelarem-se insuficiente e nos quais aparecer que o material é impróprio para o uso a que o comprador o destinava.

A garantia aplica-se à venda de um material para um cliente com a ressalva de que respeite os conselhos e instruções de uso e manutenção do material dados na documentação anexa que incorpora o item vendido ou as instruções dadas pela equipe Cofan. O prazo da garantia é de 6 meses para todos os novos materiais.

Esta garantia apenas se refere a esses mesmos materiais sem considerar outros danos que possam resultar.

RECLAMAÇÕES

Por acordo expresso, os tribunais competentes serão da nossa escolha para responder a quaisquer dificuldades que podem surgir a partir da aplicação ou interpretação do destes acordos, mesmo no caso de vários acusados (defesa) ou solicitação de garantia.



www.cofan.es





2017 CATÁLOGO GENERAL

COFAN, S.A.

Avenida de la Industria, S.N.

13610 Campo de Criptana / Ciudad REal / España

tel.: +34 926 563 928 / +34 926 563 929

Email: cofan@cofansa.com / www.cofan.es

DISTRIBUIDOR / DISTRIBUTOR:

www.cofan.es

